

Flav-R-Shield™

Full Service Sneeze Guards

Model EP11



P/N 07.14.008.00-1022 [EP11_IG]
INSTALLATION GUIDE

Model EP11 Full Service Sneeze Guards are available in ten widths ranging from 36"–144" (914–3658 mm), with a common height of 17-1/4" (438 mm). All of the widths can be configured in one of three depths including 10-7/8", 15", or 18" (276, 381, 457 mm).

For additional information regarding **Model EP11** sneeze guards, scan the QR Code below:

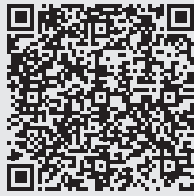

<https://www.hatcocorp.com/en/equipment/sneeze-guard-equipment/full-service/flav-r-shield-full-service-pass-over-sneeze-guard-ep11>

- c. Pre-drill the screw holes in the mounting surface.
- d. Install the flanges using the appropriate, #8 countersunk-style fasteners for the mounting surface.

Model EP11 Standard Sizes

Item Number *	Total Width (A) (post center to center)	Number of Bays	Width per Bay (post center to center)
EP11-036xx	36" (914 mm)	1	36" (914 mm)
EP11-048xx	48" (1219 mm)	2	24" (610 mm)
EP11-060xx	60" (1524 mm)	2	30" (762 mm)
EP11-072xx	72" (1829 mm)	2	36" (914 mm)
EP11-084xx	84" (2134 mm)	2	42" (1067 mm)
EP11-096xx	96" (2438 mm)	3	32" (813 mm)
EP11-108xx	108" (2743 mm)	3	36" (914 mm)
EP11-120xx	120" (3048 mm)	3	40" (1016 mm)
EP11-132xx	132" (3353 mm)	4	33" (838 mm)
EP11-144xx	144" (3658 mm)	4	36" (914 mm)

* The "xx" at the end of the Item Numbers refers to the depth of the sneeze guard. This will be "12", "15", or "18", depending on the unit ordered.

Important Safety Information

To avoid serious injury and damage to equipment or property, read the following safety information before installing this equipment.

Do not attempt to assemble and install sneeze guards alone. Installation of sneeze guards requires two or more people, dependent upon unit.

Always wear proper protective eye wear when handling glass sneeze guards.

Never spray cleaners directly onto sneeze guard surfaces. Spray cleaner into non-abrasive cloth, and then wipe down surfaces.

Use non-abrasive cleaners and cloths only. Abrasive cleaners and cloths could scratch finish of unit, marring its appearance and making it susceptible to soil accumulation. Use of abrasive materials will void warranty.

Assembly and Installation

1. Unpack all components. Verify that the appropriate number of the items below are present.
 - Face Panel, 1/4" Tempered Glass
 - End Panel, 1/4" Tempered Glass
 - Top Panel, 1/4" Tempered Glass
 - Post Assembly, 1" Stainless Steel
 - Center Post Assembly, 1" Stainless Steel (multiple bay only)
 - Rear Support Clip (for 15" and 18" End Panels)
 - Hardware Packet (includes hex wrenches for set screws)

2. Remove the Mounting Flanges from each Post Assembly.

- a. Slide the Flange Cover up and off of the flange.
- b. Using the included hex wrench, loosen the set screw on the flange.
- c. Slide the flange off of the Post Assembly.

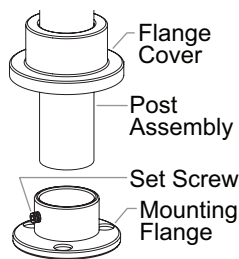

3. Install the Mounting Flanges to the mounting surface.

IMPORTANT NOTE

Sneeze guards that consist of multiple bays require careful measurement before installation of the Mounting Flanges.

- a. Refer to the "Model EP11 Standard Sizes" chart and illustration below to determine the location of the flanges. For multiple bay installations, refer to "Width per Bay" column in the chart.
- b. Position the flanges in the appropriate locations, and mark the screw hole locations. **IMPORTANT!** Measure carefully, and make sure the flanges remain square to each other as well as the installation location.

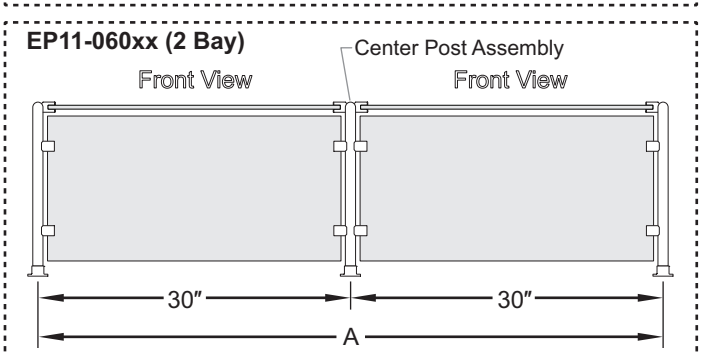
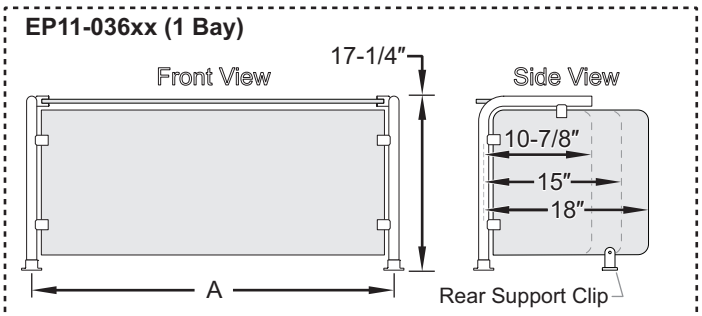

NOTE: NSF Standards require the use of 18" End Panels for compliance.

6. Insert each Post Assembly into its corresponding Mounting Flange. Make sure the posts are fully seated in the flanges.
7. Tighten the set screw on each Mounting Flange securely.
8. Slide each Flange Cover down onto its corresponding flange.

continued...



9. For units with extended (15" or 18") End Panels, install the Rear Support Clips to the mounting surface. The Rear Support Clips consist of a separate clip base and glass clip. To install each Rear Support Clip:
 - a. Locate the center of the clip base approximately 3" (76 mm) from the rear edge of the End Panel.
 - b. Position the clip base in the appropriate location, and mark the screw hole through the base. **IMPORTANT!** Measure carefully, and make sure each clip base remains square to each other as well as each Post Assembly.
 - c. Pre-drill the screw hole in the mounting surface.
 - d. Assemble the glass clip onto the clip base, and insert an appropriate fastener through the glass clip, the clip base, and into the pre-drilled hole in the mounting surface.

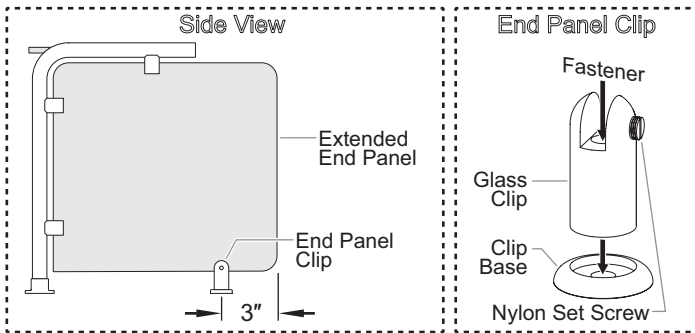

10. **IMPORTANT!** Refer to the "Securing the Glass" procedures on this sheet before beginning installation of any glass panels.
11. Install the glass Top Panel(s) by sliding it into the glass clips from the front or rear. Secure the glass.
12. Install the glass Face Panel(s) by sliding it into the glass clips from above. Secure the glass.
13. Install each glass End Panel by sliding it into the glass clips on the Post Assembly from the rear. Secure the glass.
 - For extended End Panels, make sure the End Panel is seated properly in the Rear Support Clip. Secure the glass.
14. For NSF compliance, apply NSF-approved silicone sealant to the screw heads of all set screws and nylon set screws.

NOTE: For NSF compliance, the bottom edge of all End Panels cannot be positioned higher than 1-1/2" (38 mm) above the installation surface.

Securing the Glass

Glass panels are attached to Post Assemblies using integrated glass clips. **CAUTION! Always wear proper protective eye wear when handling glass.**

Glass Clips

The glass Face, End and Top Panels are attached to the Post Assemblies using integrated glass clips. A nylon set screw on each glass clip secures the glass panel in the clip.

NOTE: During installation of all vertical and angled glass panels, Hatco strongly recommends that an abraded surface be created where the nylon set screw contacts the glass. This will create a strong bond between the set screw and the glass. Use 320-grit sandpaper to scuff the glass where each nylon set screw will contact the glass.

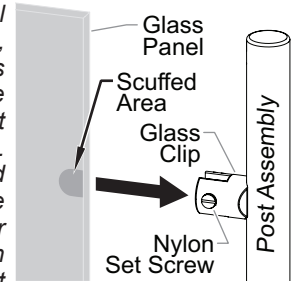

1. Abrade the surface of the glass panel where each nylon set screw will contact the glass.
2. Insert the glass panel into the glass clips.
3. Carefully turn the nylon set screw clockwise just until the screw contacts the glass. Then, turn the screw an additional 1/4-turn to secure the glass.

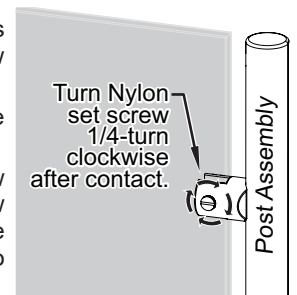

Cleaning/Maintenance

Clean the unit daily using non-abrasive cloths and cleaners.

- Always spray/apply cleaner to the cloth, then wipe down the sneeze guard. Do not spray cleaner directly onto the sneeze guard.

Custom Units

Scan this QR code or click the link below to access information regarding custom units including sizes, glass, hardware, and lighting.

www.hatcosneezeguards.com



HATCO CORPORATION
 P.O. Box 340500
 Milwaukee, WI 53234-0500 U.S.A.
 414-671-6350
support@hatcocorp.com
www.hatcocorp.com