



Project \_\_\_\_\_  
 Item # \_\_\_\_\_  
 Quantity \_\_\_\_\_

# FR Food Rethermalizers / Bain-Marie Heaters

Models: FR-3, -4, -6, -9,  
 FR-3B, -4B, -6B, -9B

The Hatco FR is designed to be used with a Bain-Marie or Food Rethermalizer to heat or hold foods at safe-serving temperatures between 140°F (60°C) to 190°F (88°C). The FR units mount under a sink or holding vessel, with water being continually circulated to avoid any "cool" spots.

## Standard features

- Equipped with an Energy Cut-Off (ECO) for built-in protection against higher-than-normal water temperature
- Desired holding temperature is maintained with an adjustable water temperature control
- Includes a power On/Off toggle switch and standard 2" (51 mm) plated brass plumbing fittings for mounting into a holding tank
- Separate sump and heating compartment drains allow for easy cleaning and sanitizing
- Shipped with a stainless steel front, powdercoated / silver-gray hammertone body and black base, and includes a five-year limited warranty



FR-6

## Options (available at time of purchase only)

- All Stainless Steel Body and Base
- Low-Water Cut-Off (Prevents element burnout from low-water conditions)
- CSA Wiring (Canada only) (Not available with cord and plug)
- Security Package (Torx® Screws and Control Cover)
- 480 Volt

## Accessories

- Flush Kit (Flush Hose, Stopper and Adapter)



IFS anti-microbial coatings use naturally-occurring, environmentally sustainable, silver ions to help inhibit the growth of microbes on the powder coated surface. See [www.hatcocorp.com/antimicrobial-paint](http://www.hatcocorp.com/antimicrobial-paint) for more information.



For operation, location and safety information, please refer to the Installation and Operating Manual.



HATCO CORPORATION | P.O. Box 340500 Milwaukee, WI 53234-0500 U.S.A. | (414) 671-6350



[www.hatcocorp.com](http://www.hatcocorp.com) | [support@hatcocorp.com](mailto:support@hatcocorp.com) | [Find a Hatco Rep](#) | [Image Library](#) | [Document Library](#) | [Patents](#) | [Chat](#)



# FR Food Rethermalizers / Bain-Marie Heaters

Models: FR-3, -4, -6, -9, FR-3B, -4B, -6B, -9B

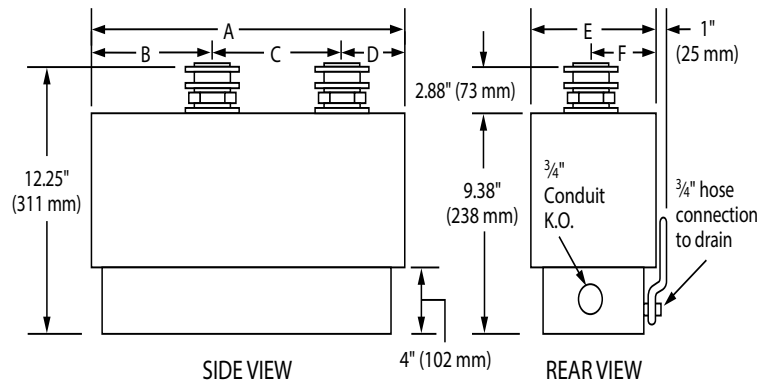

## Dimensions

Model	A	B	C	D	E	F
FR-3, -4, -6, -9 (1- or 3-Phase)	16.88" (429 mm)	5.5" (140 mm)	8.5" (216 mm)	2.88" (73 mm)	6.75" (171 mm)	3.38" (86 mm)
FR 480V <sup>✓</sup> (Bal. 3-Phase)	17.13" (435 mm)	4.63" (117 mm)	8.5" (216 mm)	4" (102 mm)	8" (203 mm)	4" (102 mm)
FR-3B, -4B, -6B, -9B (1- or 3-Phase)	17.13" (435 mm)	4.63" (117 mm)	8.5" (216 mm)	4" (102 mm)	8" (203 mm)	4" (102 mm)

✓ FR 480V Models with Balanced 3-Phase require a Transformer and Low-Water Cut-Off.

## SIZING INFORMATION

For a Bain-Marie or Steam Table: MINIMUM 750 WATTS PER SQUARE FOOT (0.8 WATTS PER SQUARE CM) of vessel top.

For a Food Rethermalizer: MINIMUM 2000 WATTS PER SQUARE FOOT (2.2 WATTS PER SQUARE CM) of vessel top.

Use one FR for a Bain-Marie up to 6' (1829 mm) long. Over 6', minimum two required.

MUST BE INSTALLED WITH A PERFORATED WATER BAFFLE. This baffle is not supplied with heater. The FR should be positioned with no more than 3' (914 mm) on either side when mounted in holding vessel. Consult factory or installation manual for fabricating details.

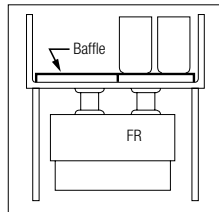

## WATER QUALITY REQUIREMENTS

Incoming water in excess of 3.0 grains of hardness per gallon (GPG) (.75 grains of hardness per liter) must be treated and softened before being supplied to hot water dispenser(s). Water containing over 3.0 GPG (.75 GPL) will decrease efficiency and reduce the operating life of the unit.

**Note: Product failure caused by liming or sediment buildup is not covered under warranty.**

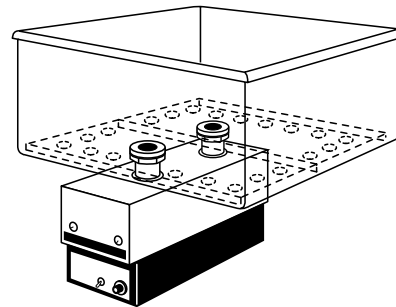

## FOOD RETHERMALIZING REQUIREMENTS

NSF Standard 4 has added performance requirements for food rethermalizing. The requirements mirror the requirements for food rethermalizing in the FDA Food Code. The basic requirement is that food reaches a temperature of 165°F (74°C) in a time period of two hours or less.

Appliances that are manufactured for the purpose of rethermalizing food will need to meet these performance requirements in order to be listed to NSF Standard 4.

The Hatco FR series heating unit is specifically made to be used for food rethermalizing, however, the heating unit is designed to be incorporated into a hot water bath rethermalizer. Hatco does not supply the vessel that contains the water, nor the system which determines how food is placed and held in the vessel. The Hatco FR2 unit simply attaches to the bottom of the vessel and supplies hot water to the vessel.

Hatco does supply sizing recommendations to enable the appliance manufacturer to correctly size the FR unit to the vessel. However, there are variables in the way that the vessel is manufactured that affect its ability to pass the NSF performance requirements. The Hatco FR unit is UL Classified on NSF 4 for construction only. Due to the fact that the FR2 is only a portion of a larger system, it is impossible to do performance testing until the FR2 unit is incorporated onto the water vessel.

The result is that it is the responsibility of the vessel manufacturer to have the entire rethermalizing appliance tested and listed in accordance with NSF Standard 4.

HATCO CORPORATION | P.O. Box 340500 Milwaukee, WI 53234-0500 U.S.A. | (414) 671-6350



[www.hatcocorp.com](http://www.hatcocorp.com) | [support@hatcocorp.com](mailto:support@hatcocorp.com) | [Find a Hatco Rep](#) | [Image Library](#) | [Document Library](#) | [Patents](#) | [Chat](#)



# FR Food Rethermalizers / Bain-Marie Heaters

Models: FR-3, -4, -6, -9, FR-3B, -4B, -6B, -9B

## SPECIFICATIONS

### FR Food Rethermalizers / Bain-Marie Heaters

Model	Voltage 50/60Hz	kW	Phase	Amps	Wiring Sizing AWG <sup>†</sup>	Fuse or Circuit Breaker <sup>◇</sup>	Approx. Ship Weight
FR-3	208	3.0	Single	14.4	12	20	24 lbs. (11 kg)
	240			12.5			
	480			6.3			
	220-230	2.5-2.8	Single	11.5-12	14	15	24 lbs. (11 kg)
	230-240	2.8-3.0		12-12.5	12	20	
FR-4	208	4.5	Single	22	10	30	24 lbs. (11 kg)
	240			18.8			
	480			9.4			
	415	4.5	Three <sup>Δ</sup>	9.4	14	15	24 lbs. (11 kg)
FR-6	208	6.0	Single	29	8	40	28 lbs. (13 kg)
	240			25			
	480			12.5			
	220-230	5.0-5.5	Single	23-24	10	30	28 lbs. (13 kg)
	230-240	5.5-6.0		24-25	8	40	
	208	6.0	Three <sup>Δ</sup>	25	8	40	28 lbs. (13 kg)
	240			21.7			
480	10.8						
415	6.0	Three <sup>Δ</sup>	14	12	20	28 lbs. (13 kg)	
FR-9	208	9.0	Single	43.3	4	60	28 lbs. (12 kg)
	240			37.5			
	480			18.8			
	208	9.0	Three <sup>Δ</sup>	37.5	6	50	28 lbs. (12 kg)
	240			32.5			
	480			16.2			

The shaded areas contain electrical information for International models only

Model	Voltage 50/60Hz	kW	Phase	Amps	Wiring Sizing AWG <sup>†</sup>	Fuse or Circuit Breaker <sup>◇</sup>	Approx. Ship Weight
FR-3B	208	3.0	Three (Bal.)	8.3	14	15	30 lbs. (14 kg)
	240			7.2			
	480			3.6			
	220-230	3.4	Three (Bal.)	8.8-9.2	14	15	30 lbs. (14 kg)
	380-400	2.3-2.5		3.4-3.5			
400-415	2.5-2.7	3.5-3.7					
FR-4B	208	4.5	Three (Bal.)	12.5	12	20	32 lbs. (15 kg)
	240			10.8			
	480			5.4			
FR-6B	208	6.0	Three (Bal.)	18.8	10	30	30 lbs. (14 kg)
	240			14.4			
	480			7.2			
	380	6.0	Three (Bal.)	10.2	14	15	30 lbs. (14 kg)
	220-230	5.0-5.5		13.2-13.8			
FR-9B	208	9.0	Three (Bal.)	25	10	40	30 lbs. (14 kg)
	240			21.7			
	480			10.8			
	380	9.0	Three (Bal.)	12.9	12	20	30 lbs. (14 kg)
	440			11.8			
	380-400			7.6-8.3			
400-415	8.3-9.0	11.9-12.5	12	20			

<sup>◇</sup> Wire size is based on THHN wire for branch circuit protection at 0.91 derate factor. Circuit breakers and fused disconnects are to be mounted remote and wired by contractor. Sizes are based on the 2002 NEC table 310-16. Conduit size based on conductors plus ground wire sizing per Table C1 from Appendix C.

<sup>†</sup> Based upon THHN wire rated 90°C.

<sup>Δ</sup> Open Delta—standard construction (Amperage higher than Balanced 3-phase).

## PRODUCT SPECS

### FR Food Rethermalizers / Bain-Marie Heaters

The electric heater shall be manufactured by the Hatco Corporation, Milwaukee, WI 53234 U.S.A.

The Hatco Model FR shall be rated at ... kW, ... volts, ... phase. The heater shall be complete with all internal plumbing and wiring ready for external installation to the bottom of the holding vessel.

The heater tank shall be of stainless steel construction and dual reservoir design; one reservoir to contain a permanently submerged heating element, the other to trap and collect soil which can be emptied easily by a convenient drain.

The heater shall be equipped with an external thermostat adjustment calibrated from 140°F (60°C) to 190°F (88°C) to control the water temperatures and an overtemperature device to protect the unit from overheating. There shall also be an indicator light to signal when water is up to temperature and another to indicate power is on.

The heater shall consist of stainless steel front and silver-gray hammertone body (or stainless steel body and base).

Warranty consists of 24/7 parts and service assistance (US and Canada only).

HATCO CORPORATION | P.O. Box 340500 Milwaukee, WI 53234-0500 U.S.A. | (414) 671-6350



[www.hatcocorp.com](http://www.hatcocorp.com)

[support@hatcocorp.com](mailto:support@hatcocorp.com)

[Find a Hatco Rep](#)

[Image Library](#)

[Document Library](#)

[Patents](#)

[Chat](#)