



Project _____

Item # _____

Quantity _____

Cashier Shield

Models: CS3040P, CS3040PNW, CS3236SP, CSHM4832, CSFLEXM1612-24

Hatco's lightweight, clear, transparent Cashier Shield can help you in your effort to prevent the spread of germs and viruses at checkout registers, restaurants, pharmacies and other customer interaction areas. It acts as a physical barrier that can limit the passing of contagions at customer interaction points. Clear partitions are more important than ever. Cashier Shield does not require tools for assembly.

Standard features

- Helps maintain social distance and physical separation
- Helps protect customers and employees
- Easily sanitized using non-abrasive cleaners
- Completely transparent/clear - will not obscure vision
- More impact resistant than glass, durable and light weight
- Rounded edges
- Easy to install
- CS3040P:
 - Convenient pass-through window at base of shield
 - .375" (10 mm) thick sturdy polycarbonate shield
 - 14 gauge Stainless Steel feet with mounting holes provided
 - Stands on its own, does not require tools for assembly
 - Feet can be secured to surface using mounting screw holes
- CS3040PNW:
 - Same features as CS3040P with no pass-through window
- CS3236SP:
 - 0.22" (5.6 mm) thick Acrylic shield
 - 1" (25 mm) square box stainless steel tubing support legs
 - Easy to assemble without tools (simple thumb screws secure shield to legs)
 - Legs have screw holes for secure mounting
 - Shield stands at a 55° angle
 - Stands on its own, does not require tools for assembly
 - Feet can be secured to surface using mounting screw holes
- CSHM4832:
 - 0.22" (5.6 mm) thick Acrylic shield
 - Can hang horizontally or vertically
 - 108" (4572 mm) long, 1/16" (2.6 mm) Stainless Steel cable
- CSFLEXM1612-24:
 - 0.22" (5.6 mm) thick Acrylic shield
 - Adjustable, flexible arm
 - Securely clamps to most surfaces
 - Portable
 - Easily adjusts to needed area

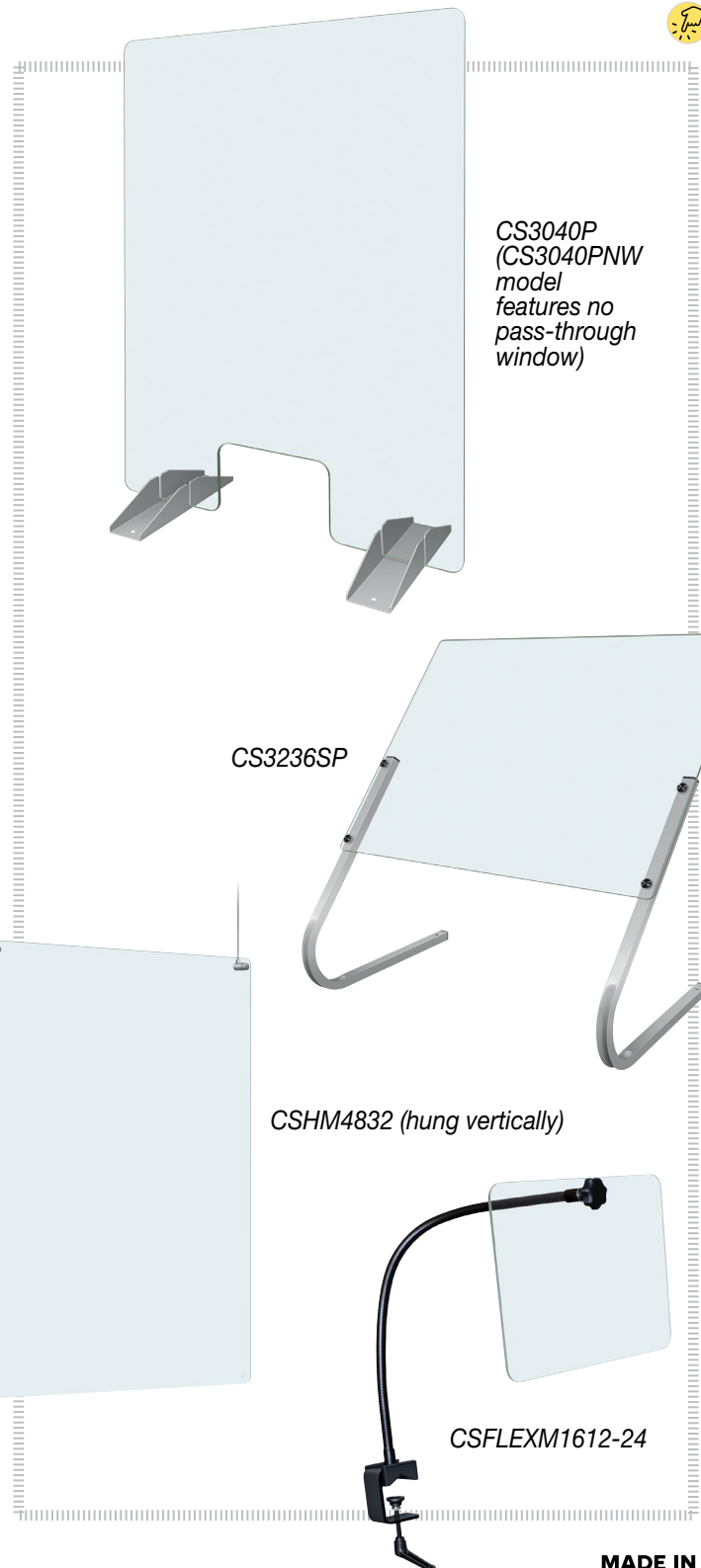

HATCO CORPORATION | P.O. Box 340500 Milwaukee, WI 53234-0500 U.S.A. | (800) 558-0607 | (414) 671-6350



www.hatcocorp.com | support@hatcocorp.com | [Find a Hatco Rep](#) | [Image Library](#) | [Document Library](#) | [Chat](#)



Cashier Shield

Model: CS3040P, CS3040PNW, CS3236SP, CSHM4832, CSFLEXM1612-24

CS3040P

CS3040PNW (same dimensions as CS3040P but without pass-through)

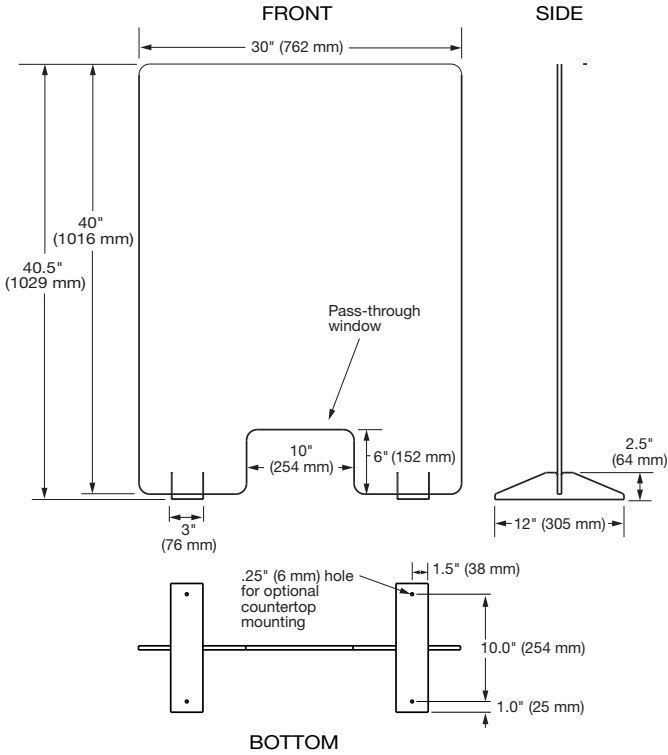

CS3236SP

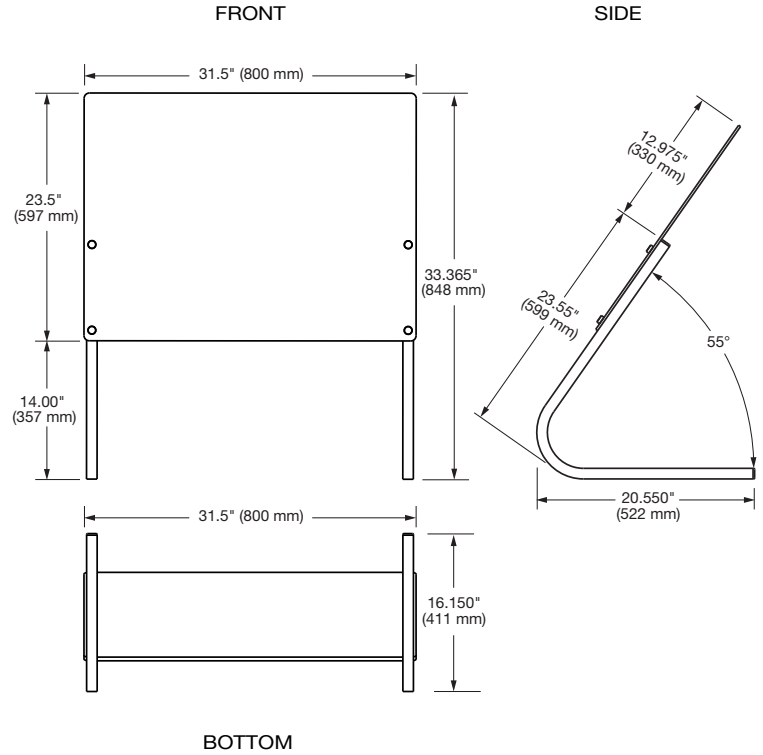

CSHM4832

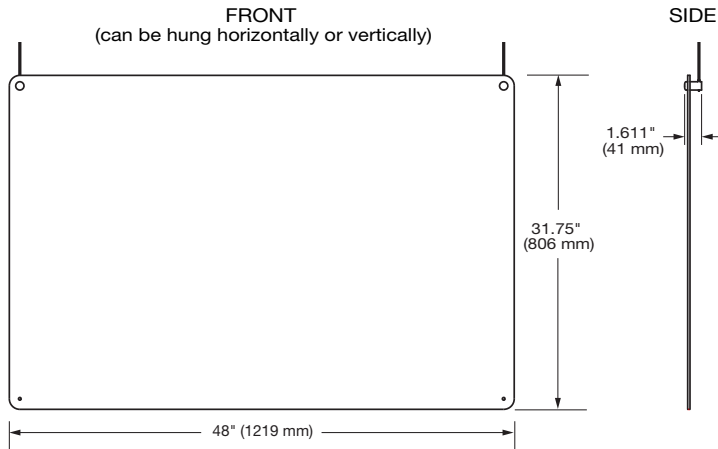

CSFLEXM1612-24

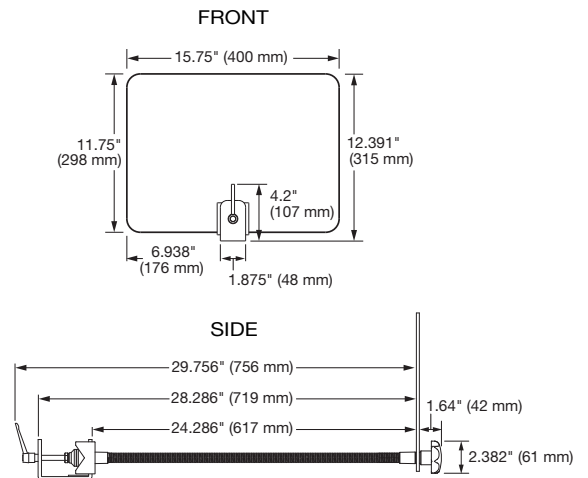



Cashier Shield

Model: CS3040P, CS3040PNW, CS3236SP, CSHM4832, CSFLEXM1612-24

SPECIFICATIONS Cashier Shield

Model	Model Dimensions* (W x D x H)	Package Dimensions (W x D x H)	Approximate Shipping Weight
CS3040P *	30" x 12" x 40.5" (762 x 305 x 1029 mm)	33" x 4" x 47" (838 x 102 x 1194 mm)	26 lbs. (12 kg.)
CS3040PNW *	30" x 12" x 40.5" (762 x 305 x 1029 mm)	33" x 4" x 47" (838 x 102 x 1194 mm)	26 lbs. (12 kg.)
CS3236S †	31.5" x 20.55" x 33.365" (800 x 522 x 848 mm)	26" x 4" x 34" (660 x 102 x 864 mm)	15 lbs. (7 kg.)
CSHM4832 †	48" x 1.611" x 31.75" (1219 x 41 x 807 mm)	Pending	Pending
CSFLEXM1612-24 †	15.75" x 12.391" x 31.616" (400 x 315 x 803 mm)	Pending	Pending

* Polycarbonate is .375" (10 mm) thick

† Acrylic is .022" (5.6 mm) thick

PRODUCT SPECS Cashier Shields

The Cashier Shield shall be a Hatco model ... , as manufactured by the Hatco Corporation, Milwaukee, WI 53234, U.S.A.

The unit shall have ... a polycarbonate shield with Stainless Steel base feet (CS3040P) or acrylic shield with square tubing support legs (CS3236SP).

The CS3040P and CS3040PNW Cashier Shields shall have a .375" (10 mm) clear polycarbonate shield with 14 gauge Stainless Steel base feet (Mounting Brackets) with holes which offer a Counter Mount Option, the CS3040P shall offer a pass-

through window at base of shield, the CS3040PNW offers no pass-through. The CS3236SP Cashier Shield shall have 0.22" (5.6 mm) clear Acrylic shield with 1" (25 mm) square box Stainless Steel tubing support legs, legs shall have screw holes for secure mounting and shield stands at a 55° angle. The CSHM4832 shall have 0.22" (5.6 mm) clear Acrylic shield, two wire rope clips, 108" (2743 mm) long, 1/16" (2.6 mm) Stainless Steel cable. The CSFLEXM1612-24 shall include a .022" (5.6 mm) clear Acrylic shield, black plastic handle, matte black flexible arm, rubber adapter and clamp.

HATCO CORPORATION

| P.O. Box 340500 Milwaukee, WI 53234-0500 U.S.A. |

(800) 558-0607 |

(414) 671-6350



www.hatcocorp.com |

support@hatcocorp.com |

[Find a Hatco Rep](#) |

[Image Library](#) |

[Document Library](#) |

[Chat](#)