



Project \_\_\_\_\_

Item # \_\_\_\_\_

Quantity \_\_\_\_\_

# Dry Soup Wells

Models:

SWC-7QT, -11QT

SWB-7QT, -11QT

Hatco's Dry Soup Wells offer a plumbing-free solution for rethermalizing or holding food at safe temperatures. Both the built-in and countertop units offer the same intuitive user interface, four customizable presets and six preset temperatures to make the Dry Soup Well a simple and effective solution.

## Standard features

- Gentle, even heating without the need for water
- Features an intuitive, interactive user interface
- Adjustable stir timers indicate when it's time to stir
- Automatically transfers from rethermalization to hold
- Features a screen lock to keep anyone else from tampering with the controls
- Pre-programmed with 4 customizable presets and 6 preset temperatures
- Pan and hinged lid included
- SWB models include a 6.56' (2000 mm) conduit for convenient placement of controls



## Options (available at time of purchase only)

Color Finishes (Countertop models only)

- Clear Anodized
- Bold Black

## Accessories (available after purchase)

Hinged Lids

- Hinged Lid for 11-Quart (10-Liter) Round Pan
- Hinged Lid for 7-Quart (7-Liter) Round Pan

Notched Lids

- Notched, Solid Lid for 11-Quart (10-Liter) Round Pan
- Notched, Solid Lid for 7-Quart (7-Liter) Round Pan

Pans

- 11-Quart (10-Liter) Round Pan
- 7-Quart (7-Liter) Round Pan



IFS anti-microbial coatings use naturally-occurring, environmentally sustainable, silver ions to help inhibit the growth of microbes on the powder coated surface. See [www.hatcocorp.com/antimicrobial-paint](http://www.hatcocorp.com/antimicrobial-paint) for more information.



For operation, location and safety information, please refer to the Installation and Operating Manual.



ANSI/NSF 4

HATCO CORPORATION | P.O. Box 340500 Milwaukee, WI 53234-0500 U.S.A. | (414) 671-6350



[www.hatcocorp.com](http://www.hatcocorp.com) | [support@hatcocorp.com](mailto:support@hatcocorp.com) | [Find a Hatco Rep](#) | [Image Library](#) | [Document Library](#) | [Patents](#) | [Chat](#)



# Dry Soup Wells

Models: SWC-7QT, SWC-11QT, SWB-7QT, SWB-11QT

## SWC, SWB MODELS

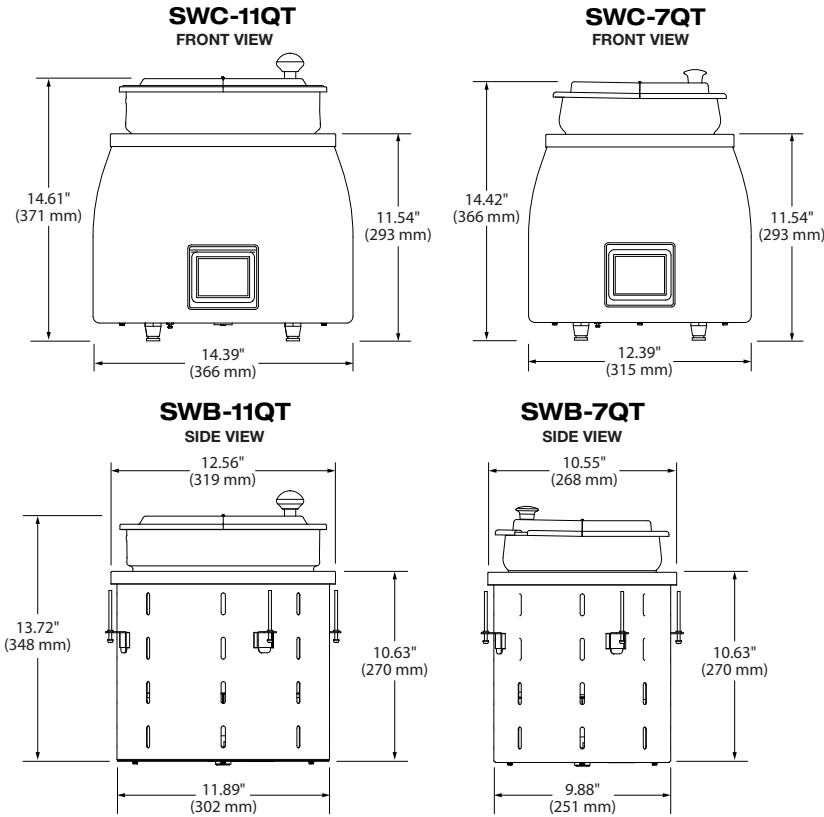

### COUNTERTOP CUTOUT SIZE

[See Installation and Operating Manuals for more information](#)

Model	Width (in diameter)	
SWB-7QT	10.11" (257 mm)	
SWB-11QT	12.125" (308 mm)	
All Models	Width	Height
Control Box Cut Out Dimensions	5.25" (133.35 mm)	4.75" (120.65 mm)

## SPECIFICATIONS Dry Soup Wells

Model	Dimensions* (W x H)	Volts	Watts	Amps	Hertz	Plug	Cord Location	Approx. Ship Weight
SWC-7QT	12.39" x 11.54" (315 mm x 293 mm)	120	425	3.5	60	NEMA 5-15P	Rear center bottom base	14 lbs. (6 kg)
SWC-11QT	14.39" x 11.54" (366 mm x 293 mm)		675	5.6				17 lbs. (7.5 kg)
SWB-7QT	10.55" x 10.63" (268 mm x 270 mm)		425	3.5				14 lbs. (6 kg)
SWB-11QT	12.56" x 10.63" (319 mm x 270 mm)		675	5.6				17 lbs. (7.5 kg)

\* Includes unit size without pan and lid.

## PRODUCT SPECS Dry Soup Wells

The Dry Soup Well shall be manufactured by the Hatco Corporation, Milwaukee, WI 53234 U.S.A.

The Dry Soup Well shall be ... , rated at ... watts, ... volts, single phase and be ... inches (millimeters) in overall width.

The Dry Soup Well shall consist of Clear Anodized or Bold Black painted patented housing (countertop versions only) and include as standard equipment

a 6.56' (2000 mm) conduit (built-in versions only) with 6' (1850 mm) power cord, a Remote Control Enclosure and mounting brackets.

The Dry Soup Well shall be factory assembled ready for electrical installation and also be pre-programmed with four customizable presets and six preset temperatures.

Warranty consists of 24/7 parts and service assistance (U.S. and Canada only).

**HATCO CORPORATION** | P.O. Box 340500 Milwaukee, WI 53234-0500 U.S.A. | (414) 671-6350



[www.hatcocorp.com](http://www.hatcocorp.com) | [support@hatcocorp.com](mailto:support@hatcocorp.com) | [Find a Hatco Rep](#) | [Image Library](#) | [Document Library](#) | [Patents](#) | [Chat](#)