

hatcocorp.com

Register Online!
(see page 2)



FLAV-R-SAVOR®

Tall Holding Cabinet

PFST Series

Installation and Operating Manual

P/N 07.04.303.00

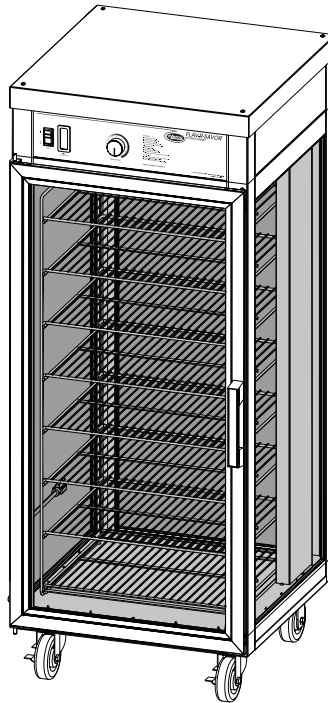

⚠ WARNING

Do not operate this equipment unless you have read and understood the contents of this manual! Failure to follow the instructions contained in this manual may result in serious injury or death. This manual contains important safety information concerning the maintenance, use, and operation of this product. If you're unable to understand the contents of this manual, please bring it to the attention of your supervisor. Keep this manual in a safe location for future reference.

⚠ ADVERTENCIA

No opere este equipo al menos que haya leído y comprendido el contenido de este manual! Cualquier falla en el seguimiento de las instrucciones contenidas en este manual puede resultar en un serio lesión o muerte. Este manual contiene importante información sobre seguridad concerniente al mantenimiento, uso y operación de este producto. Si usted no puede entender el contenido de este manual por favor pregunte a su supervisor. Almacenar este manual en una localización segura para la referencia futura.

⚠ AVERTISSEMENT

Ne pas utiliser cet équipement sans avoir lu et compris le contenu de ce manuel ! Le non-respect des instructions contenues dans ce manuel peut entraîner de graves blessures ou la mort. Ce manuel contient des informations importantes concernant l'entretien, l'utilisation et le fonctionnement de ce produit. Si vous ne comprenez pas le contenu de ce manuel, veuillez le signaler à votre supérieur. Conservez ce manuel dans un endroit sûr pour pouvoir vous y référer plus tard.

CONTENTS

Important Owner Information	2	Operation	8
Introduction	2	General	8
Important Safety Information	3	Maintenance	9
Model Description	4	General	9
Model Designation	4	Daily Cleaning	9
Specifications	4	Replacing a Display Light	9
Plug Configurations	4	Troubleshooting Guide	10
Electrical Rating Chart	5	Options and Accessories	10
Dimensions	5	Limited Warranty	11
Installation	6	Authorized Parts Distributors	Back Cover
General	6		
Reversing the Access Door	7		

IMPORTANT OWNER INFORMATION

Record the model number, serial number, voltage, and purchase date of the unit in the spaces below (specification label located on the lower side of the unit). Please have this information available when calling Hatco for service assistance.

Model No. _____

Serial No. _____

Voltage _____

Date of Purchase _____

Register your unit!

Completing online warranty registration will prevent delay in obtaining warranty coverage. Access the Hatco website at www.hatcocorp.com, select the *Parts & Service* pull-down menu, and click on "Warranty Registration".

Business Hours: 8:00 AM to 5:00 PM Central Standard Time (CST)

(Summer Hours: June to September—
8:00 AM to 5:00 PM CST Monday–Thursday
8:00 AM to 2:30 PM CST Friday)

Telephone: 800-558-0607; 414-671-6350

E-mail: partsandservice@hatcocorp.com

Fax: 800-690-2966 (Parts and Service)
414-671-3976 (International)



24 Hour 7 Day Parts and Service Assistance available in the United States and Canada by calling 800-558-0607.

Additional information can be found by visiting our web site at www.hatcocorp.com.

INTRODUCTION

The Hatco Flav-R-Savor® Tall Holding Cabinet is designed to hold prepared foods for prolonged periods of time while maintaining that "just-made" quality. Hatco Holding Cabinets provide the best environment for food products by regulating the air temperature.

The Flav-R-Savor air flow pattern is designed to maintain consistent cabinet temperature without drying out foods. The precise heat control creates a "blanket" effect around the food. The air flow rate enables the cabinet to rapidly recover temperature after opening and closing the door.

The Flav-R-Savor Tall Holding Cabinet is a product of extensive research and field testing. The materials used were selected for maximum durability, attractive appearance, and optimum performance. Every unit is inspected and tested thoroughly prior to shipment.

This manual provides installation, safety, and operating instructions for the Flav-R-Savor Tall Holding Cabinet. Hatco recommends all installation, operating, and safety instructions appearing in this manual be read prior to installation or operation of the unit.

Safety information that appears in this manual is identified by the following signal word panels:



WARNING indicates a hazardous situation which, if not avoided, could result in death or serious injury.



CAUTION indicates a hazardous situation which, if not avoided, could result in minor or moderate injury.



NOTICE is used to address practices not related to personal injury.

IMPORTANT SAFETY INFORMATION



Read the following important safety information before using this equipment to avoid serious injury or death and to avoid damage to equipment or property.

WARNING

ELECTRIC SHOCK HAZARD:

- Plug unit into a properly grounded electrical receptacle of the correct voltage, size, and plug configuration. If plug and receptacle do not match, contact a qualified electrician to determine and install proper voltage and size electrical receptacle.
- Turn OFF power switch, unplug power cord, and allow unit to cool before performing any cleaning, adjustments, or maintenance.
- Unit is not weatherproof. Locate unit indoors where ambient air temperature is a minimum of 70°F (21°C).
- DO NOT submerge or saturate with water. Unit is not waterproof. Do not operate if unit has been submerged or saturated with water.
- Do not clean unit when it is energized or hot.
- Do not steam clean or use excessive water on the unit
- This unit is not “jet-proof” construction. Do not use jet-clean spray to clean this unit.
- Do not pull unit by power cord.
- Discontinue use if power cord is frayed or worn.
- Do not attempt to repair or replace a damaged power cord. Cord must be replaced by an Authorized Hatco Service Agent or a person with similar qualifications.
- This unit must be serviced by qualified personnel only. Service by unqualified personnel may lead to electric shock or burn.
- Use only Genuine Hatco Replacement Parts when service is required. Failure to use Genuine Hatco Replacement Parts will void all warranties and may subject operators of the equipment to hazardous electrical voltage, resulting in electrical shock or burn. Genuine Hatco Replacement Parts are specified to operate safely in the environments in which they are used. Some aftermarket or generic replacement parts do not have the characteristics that will allow them to operate safely in Hatco equipment.

FIRE HAZARD: Locate unit a minimum of 1” (25 mm) from combustible walls and materials. If safe distances are not maintained, discoloration or combustion could occur.

Use only light bulbs that meet or exceed National Sanitation Foundation (NSF) standards and are specifically designed for food holding areas. Breakage of light bulbs not specially-coated could result in personal injury and/or food contamination.

WARNING

Make sure all operators have been instructed on the safe and proper use of the unit.

This unit is not intended for use by children or persons with reduced physical, sensory, or mental capabilities. Ensure proper supervision of children and keep them away from unit.

This unit has no “user-serviceable” parts. If service is required on this unit, contact an Authorized Hatco Service Agent or contact the Hatco Service Department at 800-558-0607 or 414-671-6350; fax 800-690-2966; or International fax 414-671-3976.

CAUTION

BURN HAZARD: Some exterior surfaces on unit will get hot. Use caution when touching these areas.

Locate unit in an area that is convenient for use. Location should be level to prevent unit or its contents from falling accidentally and strong enough to support weight of unit and contents.

Transport unit in upright position only. Failure to do so may result in damage to unit or personal injury.

NOTICE

Do not lay unit on the side with the control panel. Damage to unit could occur.

Use non-abrasive cleaners and cloths only. Abrasive cleaners and cloths could scratch finish of unit, marring its appearance and making it susceptible to soil accumulation.

Clean unit daily to avoid malfunctions and maintain sanitary operation.

Do not use harsh chemicals such as bleach, cleaners containing bleach, or oven cleaners to clean unit.

MODEL DESCRIPTION

All Models

Flav-R-Savor® Tall Holding Cabinets are made of sturdy extruded aluminum and stainless steel and come with a full-view tempered glass door as well as tempered glass sides.

Cabinets also feature tempered glass sides, incandescent lights to illuminate the cabinet interior, a temperature control to regulate the heat, and a temperature monitor to indicate cabinet temperature.

Units have an eight-shelf rack with 5" (127 mm) on center clearances that is capable of holding a maximum of 16 pizza boxes or eight bagged pizzas. Cabinets also have heavy-duty 5" (127 mm) locking casters for easy portability.

Model PFST-1X

The PFST-1X is a single door model.

Model PFST-2X

The PFST-2X is equipped with front and rear access doors.

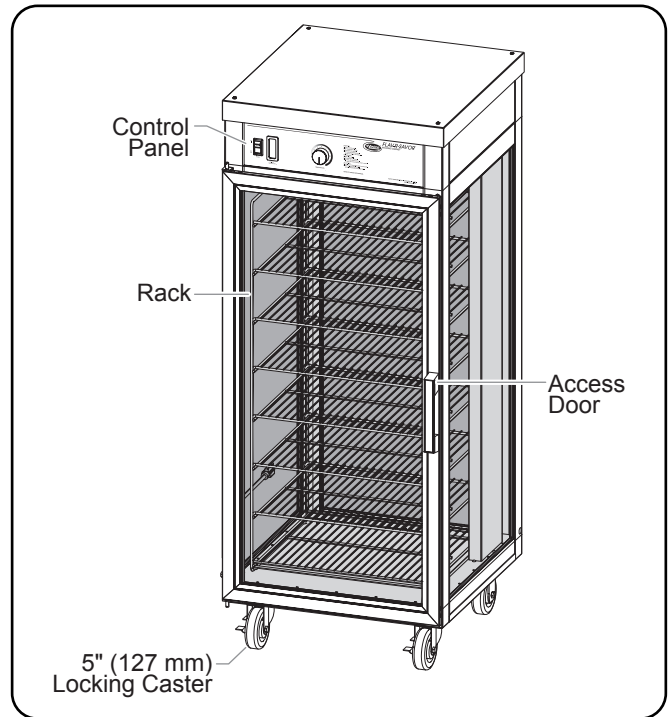

Model PFST-2X

MODEL DESIGNATION

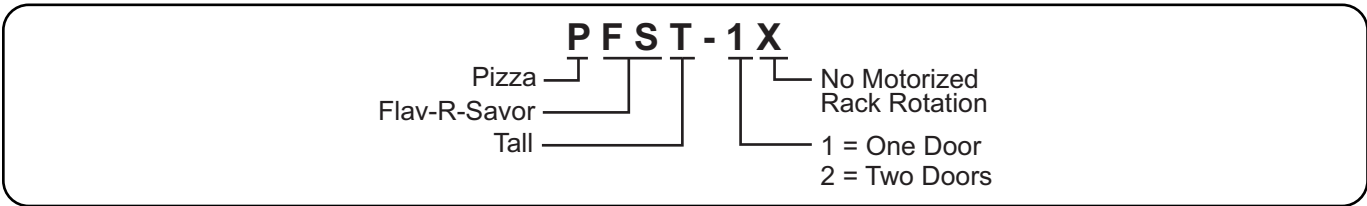

SPECIFICATIONS

Plug Configurations

Units are supplied from the factory with an electrical cord and plug installed. Plugs are supplied according to the applications.



ELECTRIC SHOCK HAZARD: Plug unit into a properly grounded electrical receptacle of the correct voltage, size, and plug configuration. If plug and receptacle do not match, contact a qualified electrician to determine and install proper voltage and size electrical receptacle.

NOTE: Specification label located on the lower side of the unit. See label for serial number and verification of unit electrical information.

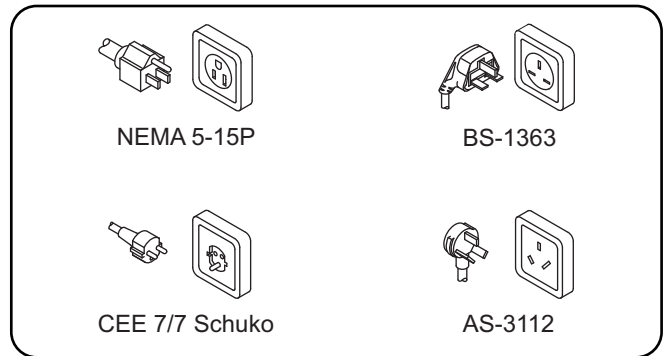

Plug Configurations

NOTE: Receptacle not supplied by Hatco.

SPECIFICATIONS

Electrical Rating Chart

Model	Voltage	Hertz	Watts	Amps	Plug Configuration	Unit Weight
PFST-1X	120	60	1767	14.7	NEMA 5-15P *	178 lbs. (81 kg)
	220	50/60	1747	7.9	CEE 7/7 Schuko	178 lbs. (81 kg)
	240	50/60	1767	7.4	BS-1363	178 lbs. (81 kg)
PFST-2X	120	60	1767	14.7	NEMA 5-15P *	178 lbs. (81 kg)
	220	50/60	1747	7.9	CEE 7/7 Schuko	178 lbs. (81 kg)
	240	50/60	1767	7.4	BS-1363	178 lbs. (81 kg)

* NEMA 5-20P for Canada

The shaded areas contain electrical information for International models only.

Dimensions

Model	Width (A)	Depth (B)	Height (C)	Interior Width (D)	Interior Height (E)
PFST-1X	22-7/8" (579 mm)	25" (635 mm)	57" (1446 mm)	21-1/4" (540 mm)	41" (1043 mm)
PFST-2X	22-7/8" (579 mm)	27-1/4" (692 mm)	57" (1446 mm)	21-1/4" (540 mm)	41" (1043 mm)

Rack Dimensions:

18-1/2" W x 16" D x 38-1/4" H (470 x 406 x 972 mm)

Cabinet Opening:

18-3/4" W x 40-3/8" H (476 x 1026 mm)

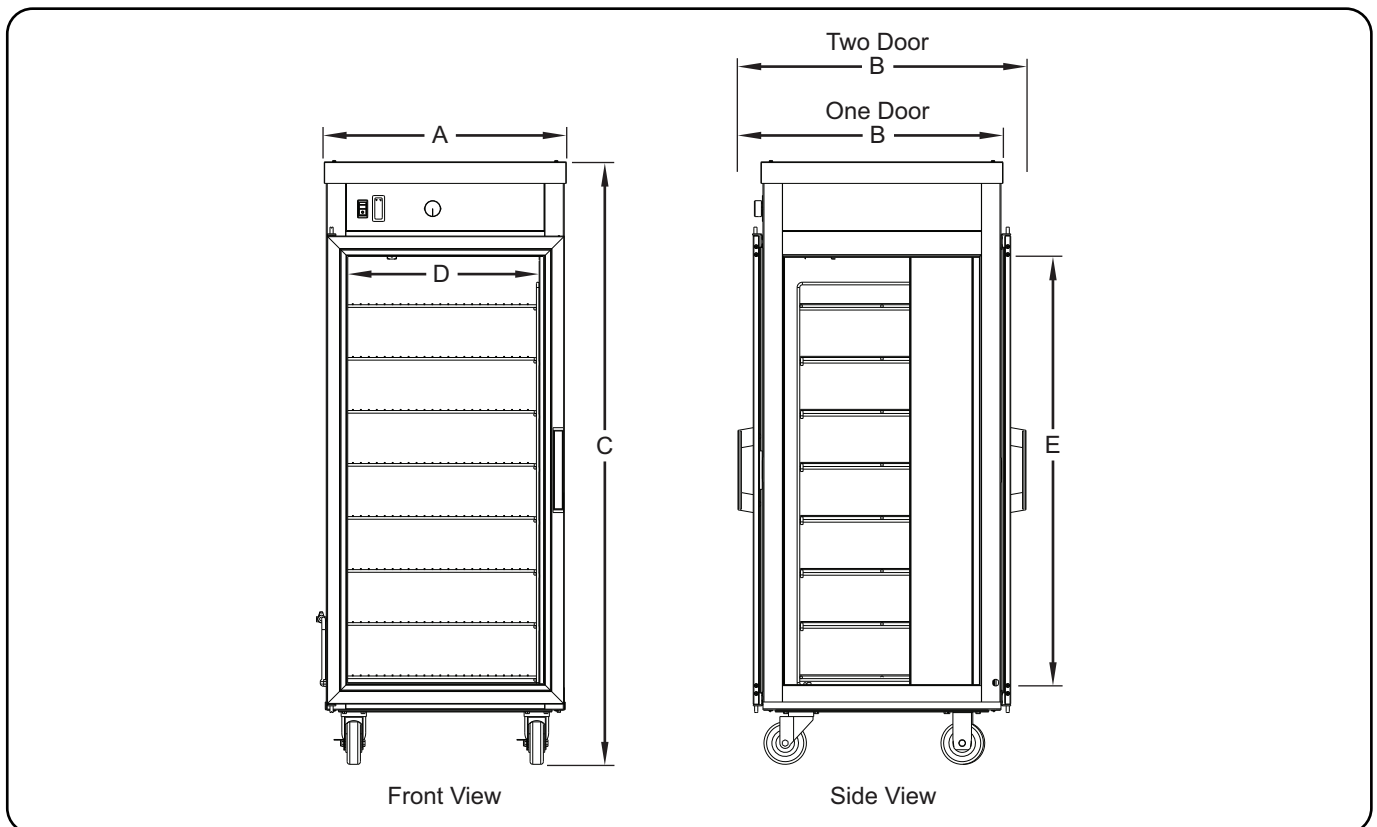

INSTALLATION

General

Flav-R-Savor® Tall Holding Cabinets are shipped with most components pre-assembled. Care should be taken when unpacking the shipping carton to avoid damage to unit and components enclosed.

⚠ WARNING

ELECTRIC SHOCK HAZARD: Unit is not weatherproof. Locate unit indoors where ambient air temperature is a minimum of 70°F (21°C).

FIRE HAZARD: Locate unit a minimum of 1" (25 mm) from combustible walls and materials. If safe distances are not maintained, discoloration or combustion could occur.

⚠ CAUTION

Locate unit in an area that is convenient for use. Location should be level to prevent unit or its contents from falling accidentally and strong enough to support weight of unit and contents.

NOTICE

Do not lay unit on the side with the control panel. Damage to unit could occur.

1. Remove the unit from the carton. Two people are required for this step.

NOTE: To prevent delay in obtaining warranty coverage, complete online warranty registration. See the IMPORTANT OWNER INFORMATION section for details.

2. Remove tape, protective packaging, and contents from the interior of the unit.
3. Install the handle(s) to the access door(s) using the hardware provided.
4. Carefully lay the unit on its side and attach the 5" (127 mm) locking casters using the mounting hardware provided. Return the unit to its upright position.
5. Place the unit in the desired location.
 - Locate the unit in an area where the ambient air temperature is constant and a minimum of 70°F (21°C). Avoid areas that may be subject to active air movements or currents (i.e., near exhaust fans/hoods, air conditioning ducts, outside door openings).
 - Make sure the floor is level and strong enough to support the weight of the unit and food product.
6. Plug the unit into a properly grounded electrical receptacle of the correct voltage, size and plug configuration. See the SPECIFICATIONS section for details.

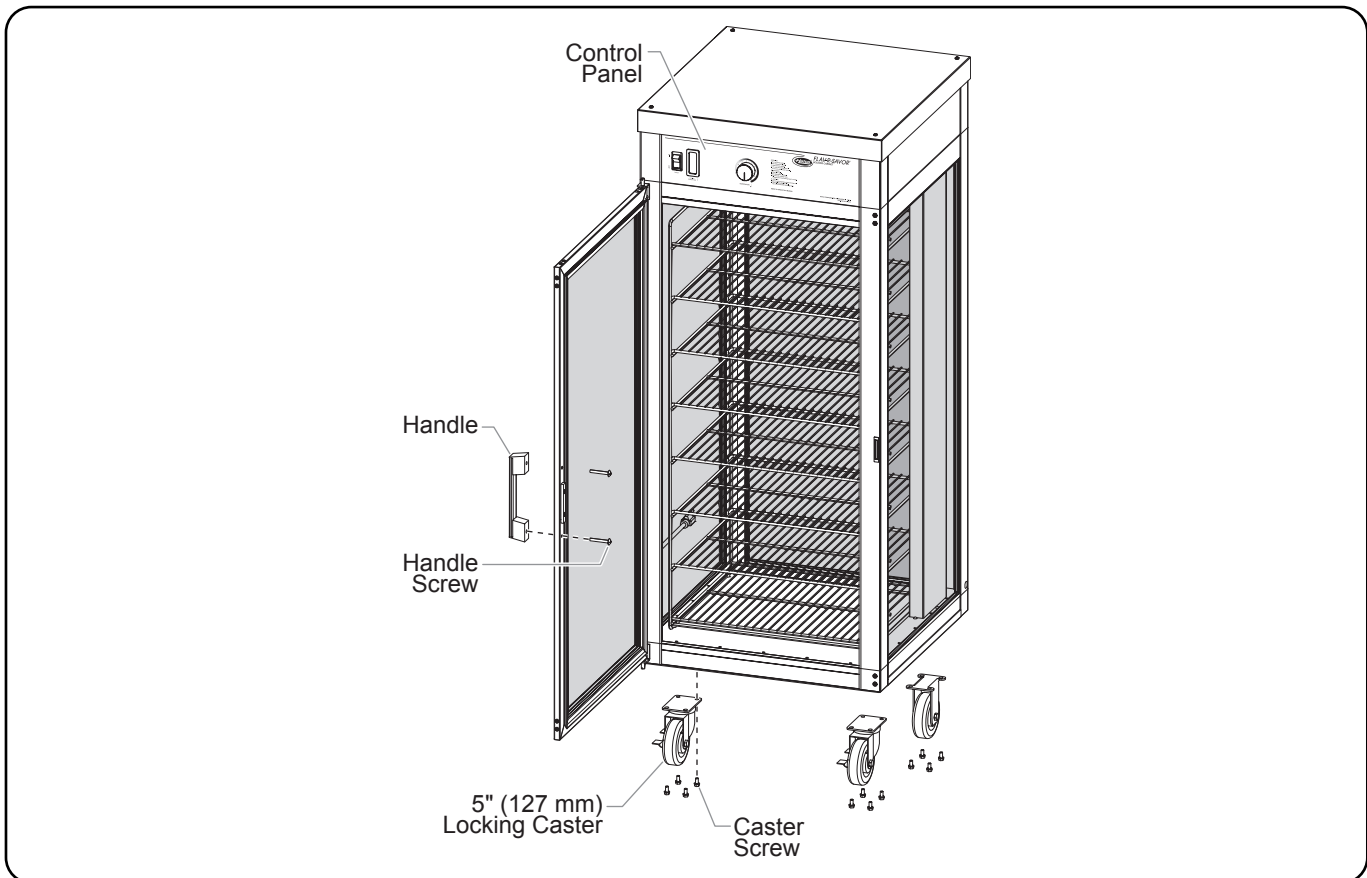

Installing Flav-R-Savor Tall Holding Cabinets

Reversing the Access Door

Doors are shipped from the factory mounted on the left side of the cabinet, opening from the right. Use the following procedure to reverse the door to open from the left.

1. Remove the top hinge screw. Make sure to locate and save the top nylon washer.
2. Tip the door forward (away from cabinet) and lift gently to clear the bottom hinge bracket. Remove the bottom nylon washer.
3. Reinstall the hinge screw that was removed in the first step.
4. Remove the bracket screws securing each hinge bracket to the cabinet.
5. Remove the hole plug screws from the right side of the cabinet and install them into the left-side screw holes.
6. Rotate the door 180°.
7. Remove the hinge screw from the end of the door that is now the top.
8. Place the door assembly into the bottom hinge bracket while holding the thick nylon washer on the bottom hinge screw.

NOTE: Nylon washers must be installed between the door and the hinge brackets.

9. Tip/tilt the door assembly towards the cabinet and align the door top with the hinge bracket. Reinstall the top hinge screw through the hinge bracket, through the thin nylon washer, and into the door top. Tighten securely.

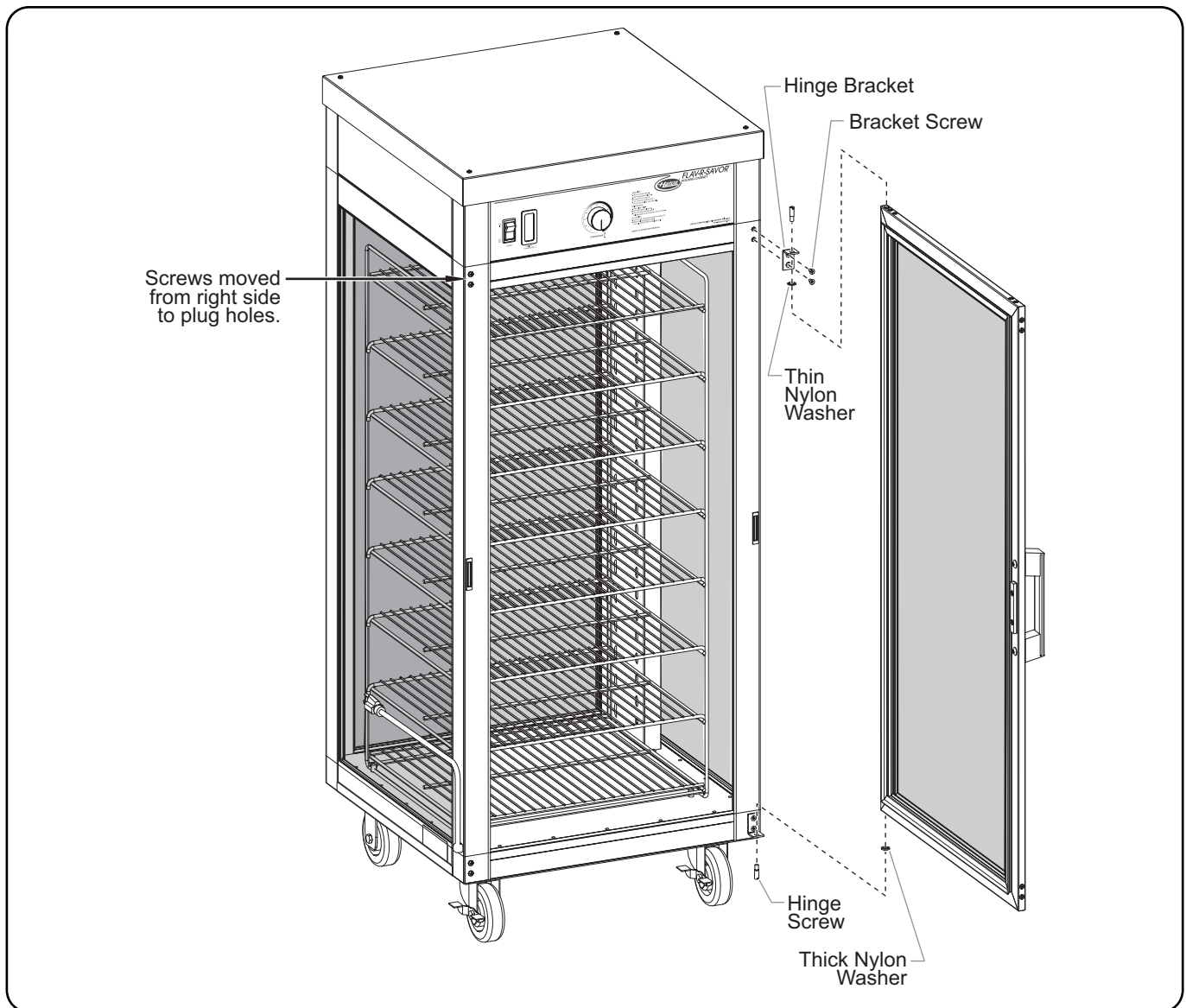

Reversing Access Door

OPERATION

General

Use the following procedures to operate the Flav-R-Savor® Tall Holding Cabinet.



Read all safety messages in the **IMPORTANT SAFETY INFORMATION** section before operating this equipment.

Startup

1. Plug unit into a properly grounded electrical receptacle of the correct voltage, size, and plug configuration. See the SPECIFICATIONS section for details.
2. Move the POWER ON/OFF (I/O) switch to the ON (I) position.



BURN HAZARD: Some exterior surfaces on unit will get hot. Use caution when touching these areas.

3. Set the TEMPERATURE Control to the desired temperature setting.

NOTE: Temperature settings may vary depending upon product make-up and consistency. The cabinet temperature indicator displays the lowest temperature point inside the cabinet, not the product temperature.

4. Allow the unit 30 minutes to reach operating temperature.

Shutdown

1. Move the Power ON/OFF (I/O) switch to the OFF (O) position.
2. Allow the unit to cool, and perform the “Daily Cleaning” procedure in the MAINTENANCE section.

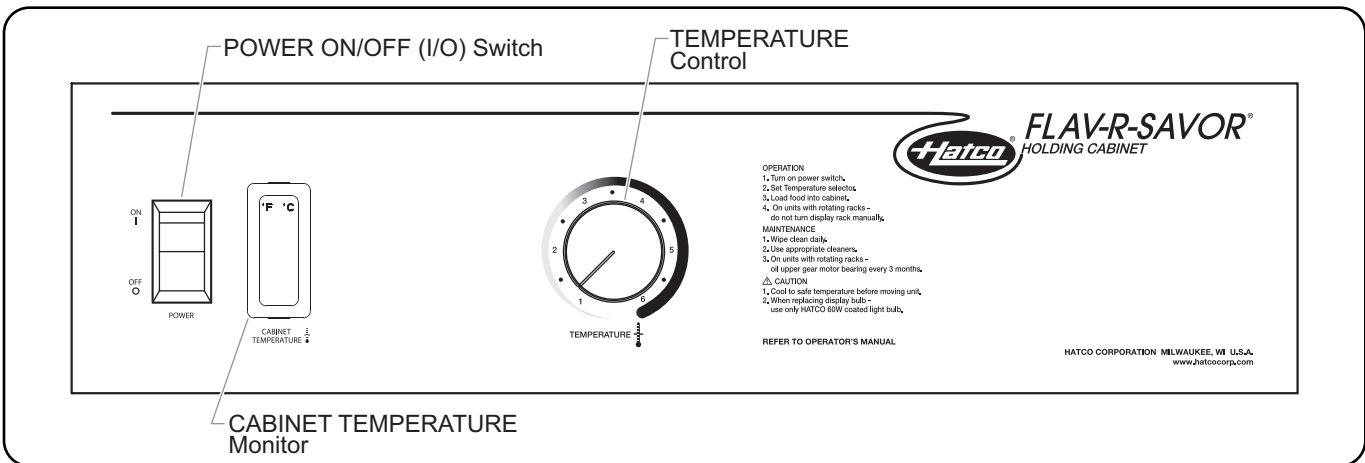

Control Panel

General

Flav-R-Savor Tall Holding Cabinets are designed for maximum durability and performance, with minimum maintenance.



ELECTRIC SHOCK HAZARD:

- Turn OFF power switch, unplug power cord, and allow unit to cool before performing any cleaning, adjustments, or maintenance.
- DO NOT submerge or saturate with water. Unit is not waterproof. Do not operate if unit has been submerged or saturated with water.
- Do not clean unit when it is energized or hot.
- Do not steam clean or use excessive water on unit.
- This unit is not “jet-proof” construction. Do not use jet-clean spray to clean unit.
- Use only Genuine Hatco Replacement Parts when service is required. Failure to use Genuine Hatco Replacement Parts will void all warranties and may subject operators of the equipment to hazardous electrical voltage, resulting in electrical shock or burn. Genuine Hatco Replacement Parts are specified to operate safely in the environments in which they are used. Some aftermarket or generic replacement parts do not have the characteristics that will allow them to operate safely in Hatco equipment.

This unit has no “user-serviceable” parts. If service is required on this unit, contact an Authorized Hatco Service Agent or contact the Hatco Service Department at 800-558-0607 or 414-671-6350; fax 800-690-2966; or International fax 414-671-3976.

Daily Cleaning

To preserve the finish of the unit, perform the following cleaning procedure daily.

NOTICE

Use non-abrasive cleaners and cloths only. Abrasive cleaners and cloths could scratch finish of unit, marring its appearance and making it susceptible to soil accumulation.

Do not use harsh chemicals such as bleach, cleaners containing bleach, or oven cleaners to clean unit.

1. Turn off the unit, unplug the power cord, and allow the unit to cool.
2. Remove all food pans and the rack from the interior of the cabinet.
3. Wipe down all interior and exterior metal surfaces with a clean, damp cloth. Stubborn stains may be removed with a good non-abrasive cleaner. Clean hard to reach areas using a small brush and mild soap.
4. Clean glass using ordinary glass cleaner and a damp, soft cloth or paper towel.
5. Clean and sanitize the rack using a clean, damp cloth and a sanitizer approved for food contact surfaces.
6. Wipe dry the entire unit using a non-abrasive, dry cloth.

Replacing a Display Light



Use only light bulbs that meet or exceed National Sanitation Foundation (NSF) standards and are specifically designed for food holding areas. Breakage of light bulbs not specially-coated could result in personal injury and/or food contamination.

The display lights are incandescent light bulbs that illuminate the warming area. Each bulb has a special coating to guard against injury and food contamination in the event of breakage.

1. Turn off the unit, unplug the power cord, and allow the unit to cool.
2. Unscrew the light bulb from the unit and replace it with a new, specially-coated incandescent light bulb.

NOTE: Hatco shatter-resistant light bulbs meet NSF standards for food holding and display areas. For 100 and 120 V applications, use Hatco P/N 02.30.043.00. For 220 V applications, use Hatco P/N 02.30.058.00.

TROUBLESHOOTING GUIDE



This unit must be serviced by trained and qualified personnel only. Service by unqualified personnel may lead to electric shock or burn.



ELECTRIC SHOCK HAZARD: Turn OFF power switch, unplug power cord, and allow unit to cool before performing any cleaning, adjustments, or maintenance.

Symptom	Probable Cause	Corrective Action
Display light(s) not working.	Incandescent lamp loose or defective.	Tighten or replace incandescent lamp. See MAINTENANCE section for lamp P/Ns.
	POWER ON/OFF (I/O) switch turned off.	Move POWER ON/OFF (I/O) switch to ON (I) position.
Unit operates, but is not circulating air inside cabinet.	Blower motor is defective.	Contact Authorized Service Agent or Hatco for assistance.
	Incorrect voltage supplied to unit.	Contact Authorized Service Agent or Hatco for assistance.
No heat or light.	No power to unit.	Check electrical receptacle and verify that power supply matches specifications on unit. If receptacle is not working, check circuit breaker and reset, or plug unit into a different known working receptacle.
	Power cord connections are loose or disconnected.	Contact Authorized Service Agent or Hatco for assistance.
	Power cord is damaged.	Contact Authorized Service Agent or Hatco for assistance.
	Defective POWER ON/OFF (I/O) switch.	Contact Authorized Service Agent or Hatco for assistance.
Food cavity not hot enough.	Safety high-limit is tripped or open.	Contact Authorized Service Agent or Hatco for assistance.
	Incorrect voltage supplied to heating element.	Contact Authorized Service Agent or Hatco for assistance.
	Blower motor is not working.	Check blower motor—refer to Symptom “Unit operates, but is not circulating air inside cabinet.”
	Air heating element is defective.	Contact Authorized Service Agent or Hatco for assistance.

Troubleshooting Questions?

If you continue to have problems resolving an issue, please contact the nearest Authorized Hatco Service Agency or Hatco for assistance. To locate the nearest Service Agency, log onto the Hatco website at www.hatcocorp.com and click on *Find Service Agent*, or contact the **Hatco Parts and Service Team** at:

Telephone: 800-558-0607 or 414-671-6350

e-mail: partsandservice@hatcocorp.com

Fax: 800-690-2966 or 414-671-3976

OPTIONS AND ACCESSORIES

Plastic-Coated Removable Shelves

Plastic-coated removable shelves are available to replace the standard removable shelves on the rack.



LIMITED WARRANTY

1. PRODUCT WARRANTY

Hatco warrants the products that it manufactures (the "Products") to be free from defects in materials and workmanship, under normal use and service, for a period of one (1) year from the date of purchase when installed and maintained in accordance with Hatco's written instructions or 18 months from the date of shipment from Hatco. Buyer must establish the Product's purchase date by registering the Product with Hatco or by other means satisfactory to Hatco in its sole discretion.

Hatco warrants the following Product components to be free from defects in materials and workmanship from the date of purchase (subject to the foregoing conditions) for the period(s) of time and on the conditions listed below:

- a) **One (1) Year Parts and Labor PLUS One (1) Additional Year Parts-Only Warranty:**
 - Conveyor Toaster Elements (metal sheathed)
 - Drawer Warmer Elements (metal sheathed)
 - Drawer Warmer Drawer Rollers and Slides
 - Strip Heater Elements (metal sheathed)
 - Display Warmer Elements (metal sheathed air heating)
 - Holding Cabinet Elements (metal sheathed air heating)
 - Heated Well Elements — HW and HWB Series (metal sheathed)
- b) **One (1) Year Parts and Labor PLUS Four (4) Years Parts-Only Warranty:**
 - 3CS and FR Tanks
- c) **One (1) Year Parts and Labor PLUS Nine (9) Years Parts-Only Warranty on:**
 - Electric Booster Heater Tanks
 - Gas Booster Heater Tanks
- d) **Ninety (90) Day Parts-Only Warranty:**
 - Replacement Parts

THE FOREGOING WARRANTIES ARE EXCLUSIVE AND IN LIEU OF ANY OTHER WARRANTY, EXPRESSED OR IMPLIED, INCLUDING BUT NOT LIMITED TO ANY IMPLIED WARRANTY OF MERCHANTABILITY OR FITNESS FOR A PARTICULAR PURPOSE OR PATENT OR OTHER INTELLECTUAL PROPERTY RIGHT INFRINGEMENT. Without limiting the generality of the foregoing, SUCH WARRANTIES DO NOT COVER: Coated incandescent light bulbs, fluorescent lights, heat lamp bulbs, coated halogen light bulbs, halogen heat lamp bulbs, xenon light bulbs, LED light tubes, glass components, and fuses; Product failure in booster tank, fin tube heat exchanger, or other water heating equipment caused by liming, sediment buildup, chemical attack, or freezing; or Product misuse, tampering or misapplication, improper installation, or application of improper voltage.

2. LIMITATION OF REMEDIES AND DAMAGES

Hatco's liability and Buyer's exclusive remedy hereunder will be limited solely, at Hatco's option, to repair or replacement using new or refurbished parts or Product by Hatco or a Hatco-authorized service agency (other than where Buyer is located outside of the United States, Canada, United Kingdom, or Australia, in which case Hatco's liability and Buyer's exclusive remedy hereunder will be limited solely to replacement of part under warranty) with respect to any claim made within the applicable warranty period referred to above. Hatco reserves the right to accept or reject any such claim in whole or in part. In the context of this Limited Warranty, "refurbished" means a part or Product that has been returned to its original specifications by Hatco or a Hatco-authorized service agency. Hatco will not accept the return of any Product without prior written approval from Hatco, and all such approved returns shall be made at Buyer's sole expense. HATCO WILL NOT BE LIABLE, UNDER ANY CIRCUMSTANCES, FOR CONSEQUENTIAL OR INCIDENTAL DAMAGES, INCLUDING BUT NOT LIMITED TO LABOR COSTS OR LOST PROFITS RESULTING FROM THE USE OF OR INABILITY TO USE THE PRODUCTS OR FROM THE PRODUCTS BEING INCORPORATED IN OR BECOMING A COMPONENT OF ANY OTHER PRODUCT OR GOODS.

HATCO AUTHORIZED PARTS DISTRIBUTORS

ALABAMA

Jones McLeod Appl. Svc.
Birmingham 205-251-0159

ARIZONA

Service Solutions Group
Phoenix 602-234-2443

Byassee Equipment Co.
Phoenix 602-252-0402

CALIFORNIA

Industrial Electric
Commercial Parts & Service, Inc.
Huntington Beach 714-379-7100

Chapman Appl. Service
San Diego 619-298-7106

P & D Appliance
Commercial Parts & Service, Inc.
S. San Francisco 650-635-1900

COLORADO

Hawkins Commercial Appliance
Englewood 303-781-5548

FLORIDA

Whaley Foodservice Repair
Jacksonville 904-725-7800

3Wire Nass Service Co., Inc.
Orlando 407-425-2681

B.G.S.I.
Pompano Beach 954-971-0456

Comm. Appliance Service
Tampa 813-663-0313

GEORGIA

TWC Services
Mableton 770-438-9797

Heritage Service Group
Norcross 866-388-9837

Southeastern Rest. Svc.
Norcross 770-446-6177

HAWAII

Burney's Comm. Service, Inc.
Honolulu 808-848-1466

Food Equip Parts & Service
Honolulu 808-847-4871

ILLINOIS

Parts Town
Lombard 708-865-7278

Eichenauer Elec. Service
Decatur 217-429-4229

Midwest Elec. Appl. Service
Elmhurst 630-279-8000

Cone's Repair Service
Moline 309-797-5323

INDIANA

GCS Service
Indianapolis 317-545-9655

IOWA

Goodwin Tucker Group
Des Moines 515-262-9308

KENTUCKY

Service Solutions Group
Lexington 859-254-8854

Service Solutions Group
Louisville 502-451-5411

LOUISIANA

Chandlers Parts & Service
Baton Rouge 225-272-6620

MARYLAND

Electric Motor Service
Baltimore 410-467-8080

GCS Service
Silver Spring 301-585-7550

MASSACHUSETTS

Ace Service Co., Inc.
Needham 781-449-4220

MICHIGAN

Bildons Appliance Service
Detroit 248-478-3320

Commercial Kitchen Service
Bay City 517-893-4561

Midwest Food Equip. Service
Grandville 616-261-2000

MINNESOTA

GCS Service
Plymouth 800-345-4221

MISSOURI

General Parts
Kansas City 816-421-5400

Commercial Kitchen Services
St. Louis 314-890-0700

Kaemmerlen Parts & Service
St. Louis 314-535-2222

NEBRASKA

Anderson Electric
Omaha 402-341-1414

NEVADA

Burney's Commercial
Las Vegas 702-736-0006

Hi. Tech Commercial Service
N. Las Vegas 702-649-4616

NEW JERSEY

Jay Hill Repair
Fairfield 973-575-9145

Service Plus
Flanders 973-691-6300

NEW YORK

Acme American Repairs, Inc.
Brooklyn 718-456-6544

Alpro Service Co.
Brooklyn 718-386-2515

Appliance Installation
Buffalo 716-884-7425

Duffy's Equipment Services, Inc.
Buffalo 800-836-1014

3Wire Northern
Plattsburgh 800-634-5005

Duffy's Equipment Services, Inc.
Sauquoit 800-836-1014

J.B. Brady, Inc.
Syracuse 315-422-9271

NORTH CAROLINA

Authorized Appliance
Charlotte 704-377-4501

OHIO

Akron/Canton Comm. Svc. Inc.
Akron 330-753-6635

Service Solutions Group
Cincinnati 513-772-6600

Commercial Parts and Service
Columbus 614-221-0057

Electrical Appl. Repair Service
Brooklyn Heights 216-459-8700

E. A. Wichman Co.
Toledo 419-385-9121

OKLAHOMA

Hagar Rest. Service, Inc.
Oklahoma City 405-235-2184

Krueger, Inc.
Oklahoma City 405-528-8883

OREGON

Ron's Service, Inc.
Portland 503-624-0890

PENNSYLVANIA

Elmer Schultz Services
Philadelphia 215-627-5401

FAST Comm. Appl. Service
Philadelphia 215-288-4800

Appliance Installation & Service
Pittsburgh 412-809-0244

K & D Service Co.
Harrisburg 717-236-9039

Electric Repair Co.
Reading 610-376-5444

RHODE ISLAND

Marshall Electric Co.
Providence 401-331-1163

SOUTH CAROLINA

Whaley Foodservice Repair
W. Columbia 803-791-4420

TENNESSEE

Camp Electric
Memphis 901-527-7543

TEXAS

GCS Service
Fort Worth 800-433-1804

Armstrong Repair Service
Houston 713-666-7100

Cooking Equipment Specialist
Mesquite 888-866-9276

Refrigerated Specialist, Inc.
Mesquite 888-866-9276

Commercial Kitchen Repair Co.
San Antonio 210-735-2811

UTAH

La Monica's Rest. Equip. Service
Murray 801-263-3221

VIRGINIA

Daubers
Norfolk 757-855-4097

Daubers
Springfield 703-866-3600

WASHINGTON

3Wire Restaurant Appliance
Seattle 800-207-3146

WISCONSIN

A.S.C., Inc.
Madison 608-246-3160

A.S.C., Inc.
Milwaukee 414-543-6460

CANADA

ALBERTA

Key Food Equipment Service
Edmonton 780-438-1690

BRITISH COLUMBIA

Key Food Equipment Service
Vancouver 604-433-4484

Key Food Equipment Service
Victoria 250-920-4888

MANITOBA

Air Rite, Inc.
Winnipeg 204-895-2300

NEW BRUNSWICK

EMR Services, Ltd.
Moncton 506-855-4228

ONTARIO

R.G. Henderson Ltd.
Toronto 416-422-5580

Choquette - CKS, Inc.
Ottawa 613-739-8458

QUÉBEC

Choquette - CKS, Inc.
Montreal 514-722-2000

Choquette - CKS, Inc.
Québec City 418-681-3944

UNITED KINGDOM

Marren Group
Northants +44(0)1933 665313

HATCO CORPORATION

P.O. Box 340500

Milwaukee, WI 53234-0500 U.S.A.

800-558-0607 414-671-6350

Parts and Service Fax 800-690-2966

International Fax 414-671-3976

partsandservice@hatcocorp.com

www.hatcocorp.com

Register your unit online!

See IMPORTANT OWNER INFORMATION
section for details