



Project _____
 Item # _____
 Quantity _____

Flav-R-Savor® Holding and Display Cabinets

Models: FSD-1, -1X, -2, -2X
 FSDT-1, -1X, -2, -2X

The Hatco Flav-R-Savor® offers a unique concept in food holding and display. Balancing a precise combination of heat and humidity, Flav-R-Savor Cabinets increase sales and profits by reducing waste, maintaining quality and displaying food with appealing design. Utilized in cafeterias, convenience stores, schools, restaurants and supermarkets, Flav-R-Savor Cabinets are a perfect way to merchandise your hot food items such as pizza, fried foods, bakery and more.

Our quick recovery heating system and extremely even temperatures throughout the cabinet eliminate “hot spots” and ensure consistent product quality and long hold times (1 to 4 hours)..

Standard features

- Fluorescent lights help showcase food product
- Tempered glass door and side panels provide maximum heat retention and allow for full cabinet display
- ¾ gallon (3-liters) stainless water reservoir provides all day moisture, is easily filled through the front mounted water cup and easily drained and cleaned through the inside mounted drain tube
- Low-water protection prevents heating element burnout and alerts operator to low water condition
- 120-volt operation with attached 15-amp cord set operates on a standard outlet, and draws a maximum of 12 amps
- Large access doors are field reversible and will accept a 19" (483 mm) diameter pizza pan



FSDT-1 with standard 4-tier circle rack, optional Designer Black color and accessory food pans. (decals not included)

FSD-2X with standard 3-tier pan rack, optional mechanical controls and accessory food pans. (decals not included)



Options (available at time of purchase only)

Designer Colors

- Non-standard colors are non-returnable – Anodized Aluminum standard
- Warm Red Black Gray Granite White Granite
 - Navy Blue Hunter Green Antique Copper

Mechanical Controls

- 7½" (191 mm) Display Sign Holder (one per side, three max) (sign not included)

Accessories

- 4" (102 mm) Adjustable Legs
- Motorless Rack Coupling (for -X models only)
- Racks for FSD models only
 - 5-shelf Multi-Purpose Rack 3-tier Circle Rack* 3-tier Pan Rack
- Racks for FSDT models only
 - 7-shelf Multi-Purpose Rack 4-tier Circle Rack* 5-tier Circle Rack
 - 4-tier Pan Rack 3-shelf Angle Rack 3-tier Pretzel Tree*
- Decorative Kit:
 - Two Inset Side Panels (Non-standard colors are non-returnable – Designer Black standard)
 - Crescent Wave
 - Curved Header (Non-standard colors are non-returnable – Designer Black standard)
 - Hinged for control side Non-hinged for non-control side
 - Base Skirts (requires 4" [102 mm] adjustable legs, not included) (Non-standard colors are non-returnable – Designer Black standard)
 - Flat front, back and sides Curved front, flat back and sides
 - Curved front and back, flat sides

*Requires coupling for -1X or -2X

WATER QUALITY REQUIREMENTS

Incoming water in excess of 3.0 grains of hardness per gallon (GPG) (.75 grains of hardness per liter) must be treated and softened before being supplied to booster heater(s). Water containing over 3.0 GPG (.75 GPL) will decrease the efficiency and reduce the operating life of the unit.

Note: Product failure caused by liming or sediment buildup is not covered under warranty.



HATCO CORPORATION | P.O. Box 340500 Milwaukee, WI 53234-0500 U.S.A.

(800) 558-0607 | (414) 671-6350 | www.hatcocorp.com | equipsales@hatcocorp.com | intl@hatcocorp.com



Flav-R-Savor® Holding and Display Cabinets

Models: FSD-1, -1X, -2, -2X FSDT-1, -1X, -2, -2X

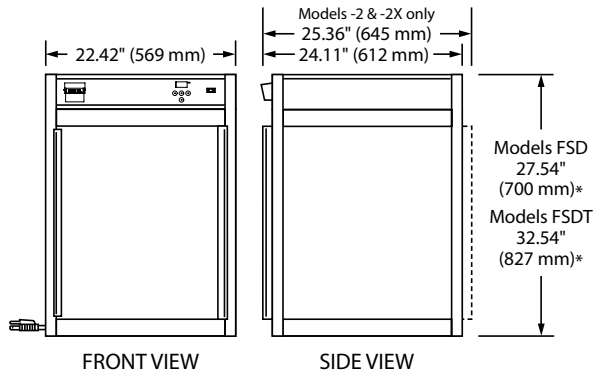

SPECIFICATIONS Holding and Display Cabinets

The shaded areas contain electrical information for International models

Model ^o	Type	Dimensions (W x D x H*)	Volts	Watts	Amps	Plug	Ship Weight*
FSD-1 and FSDT-1	FSD-1: 1 Door with 3-tier circle rack with motor	FSD-1: 22.42" x 24.11" x 27.54" (569 x 612 x 700 mm)	120	1440	12.0	NEMA 5-15P	FSD-1: 110 lbs. (50 kg) FSDT-1: 118 lbs. (54 kg)
	FSDT-1: 1 Door with 4-tier circle rack with motor	FSDT-1: 22.42" x 24.11" x 32.54" (569 x 612 x 827 mm)	220	1440	6.5	CEE 7/7 Schuko	FSD-1: 110 lbs. (50 kg) FSDT-1: 118 lbs. (54 kg)
			240	1440	6.0	BS-1363, AS 3112	
			220-230 (CE)	1440-1574	6.5-6.8	CEE 7/7 Schuko	
			230-240 (CE)	1323-1440	5.8-6.0	BS-1363	
FSD-1X and FSDT-1X	FSD-1X: 1 Door with 3-tier pan rack without motor (not available for retrofit)	FSD-1X: 22.42" x 24.11" x 27.54" (569 x 612 x 700 mm)	120	1440	12.0	NEMA 5-15P	FSD-1X: 110 lbs. (50 kg) FSDT-1X: 118 lbs. (54 kg)
	FSDT-1X: 1 Door with 4-tier pan rack without motor (not available for retrofit)	FSDT-1X: 22.42" x 24.11" x 32.54" (569 x 612 x 827 mm)	220	1440	6.5	CEE 7/7 Schuko	FSD-1X: 110 lbs. (50 kg) FSDT-1X: 118 lbs. (54 kg)
			240	1440	6.0	BS-1363, AS 3112	
			220-230 (CE)	1440-1574	6.5-6.8	CEE 7/7 Schuko	
			230-240 (CE)	1322-1440	5.8-6.0	BS-1363	
FSD-2 and FSDT-2	FSD-2: 2 Doors with 3-tier circle rack with motor	FSD-2: 22.42" x 25.36" x 27.54" (569 x 645 x 700 mm)	120	1440	12.0	NEMA 5-15P	FSD-2: 114 lbs. (52 kg) FSDT-2: 122 lbs. (55 kg)
	FSDT-2: 2 Doors with 4-tier circle rack with motor	FSDT-2: 22.42" x 25.36" x 32.54" (569 x 645 x 827 mm)	220	1440	6.5	CEE 7/7 Schuko	FSD-2: 114 lbs. (52 kg) FSDT-2: 122 lbs. (55 kg)
			240	1440	6.0	BS-1363, AS 3112	
			220-230 (CE)	1440-1574	6.5-6.8	CEE 7/7 Schuko	
			230-240 (CE)	1322-1440	5.8-6.0	BS-1363	
FSD-2X and FSDT-2X	FSD-2X: 2 Doors with 3-tier pan rack without motor (not available for retrofit)	FSD-2X: 22.42" x 25.361" x 27.54" (569 x 645 x 700 mm)	120	1440	12.0	NEMA 5-15P	FSD-2X: 112 lbs. (51 kg) FSDT-2X: 114 lbs. (52 kg)
	FSDT-2X: 2 Doors with 4-tier pan rack without motor (not available for retrofit)	FSDT-2X: 22.42" x 25.36" x 32.54" (569 x 645 x 827 mm)	220	1440	6.5	CEE 7/7 Schuko	FSD-2X: 112 lbs. (51 kg) FSDT-2X: 114 lbs. (52 kg)
			240	1440	6.0	BS-1363, AS 3112	
			220-230 (CE)	1440-1574	6.5-6.8	CEE 7/7 Schuko	
			230-240 (CE)	1322-1440	5.8-6.0	BS-1363	

^o Non-humidified cabinets available, unit will only operate in dry mode.

• Height includes standard 1" (25 mm) legs.

* Shipping weight includes packaging.

CABINET OPENING

Standard models: 19"W x 18.62" H (483 x 473 mm).

Tall models: 19"W x 23.75" H (483 x 603 mm).

CORD LOCATION

Facing controls, left-hand side panel, lower right corner.

PRODUCT SPECS

Holding and Display Cabinets

The humidity controlled Holding and Display Cabinet shall be a Flav-R-Savor® Model ..., rated at ... volts and ... watts, as manufactured by the Hatco Corporation, Milwaukee, WI 53234 U.S.A.

The cabinet shall have ... door(s), tempered glass sides, stationary rack (or revolving display), and fluorescent display lights. It shall include a water reservoir, humidity

PLUG CONFIGURATIONS

NEMA 5-15P

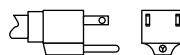

CEE 7/7 Schuko

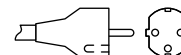

BS-1363

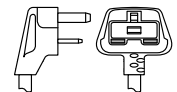

AS 3112



selector, temperature selector, On/Off switch, indicating lights, and a 6' (1829 mm) cord with plug attached.

Accessories shall include adjustable legs, display racks, pans, and merchandising display sign(s).

Warranty consists of 24/7 parts and service assistance (US and Canada only).

HATCO CORPORATION | P.O. Box 340500 Milwaukee, WI 53234-0500 U.S.A.

(800) 558-0607 | (414) 671-6350 | www.hatcocorp.com | equipsales@hatcocorp.com | intl@hatcocorp.com