



Project \_\_\_\_\_  
 Item # \_\_\_\_\_  
 Quantity \_\_\_\_\_

## Drop-In Hot/Cold Wells

Models: HCWBI-2DA, -3DA, -4DA, -5DA, -6DA

Hatco Drop-In Hot/Cold Wells combine the legendary technology of both the Hatco Heated and Refrigerated Wells into one unit to create the ultimate flexibility in your buffet line or catering needs. You can keep hot foods at safe serving temperatures during the morning hours and then switch to pre-chilled food products at the lunch hour peaks.

### Standard features

- R-513A refrigerant available for California only. Please contact Hatco for more information
- Hot/Cold Combination Drop-In Well can house a variety of pans, full-size, half-size or third-size and available in a two through six pan configuration
- Easy to read and use electronic control assembly and pan support bars
- Cold Mode: Similar to Hatco's CWB Cold Well, including auto-defrost, easy serviceability, optimal insulation and efficient condenser. Includes cold mode pan supports
- Hot Mode: Utilizes the same time-tested FR2 Hydro-Heater (Bain Marie) with "free flow" technology for an efficient and safe operation with a longer life, and includes drain, auto-fill and hot mode frame for pan support
- Adjustable set points to keep your particular food items at optimum temperatures
- Remote control box can be mounted to front counter for easy access (any vertical surface within approximately 5' (1524 mm))
- Matches the Hatco line of Refrigerated and Heated Wells for a fully integrated look
- Allow approximately 60 minutes or more for transition between operating modes of the Drop-In Hot/Cold Well

**For operation, location and safety information, please refer to the Installation & Operating Manual.**

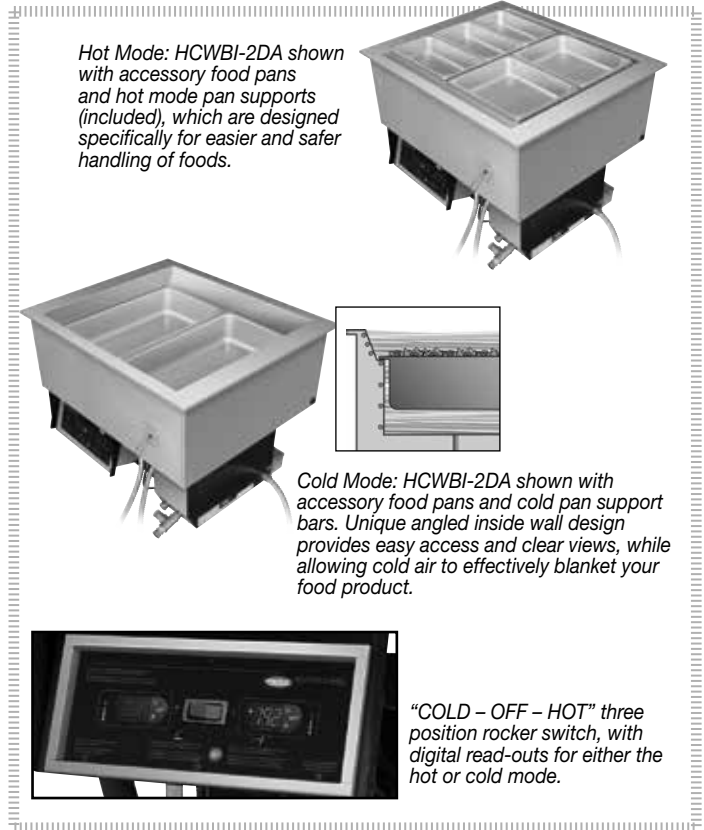

### Options (available at time of purchase only)

- Additional Four Year Parts Only Warranty on the Compressor
- Three-Phase Wiring

### Accessories

- FR2: Flush Hose, Cleaning Brush, Stopper and Adapter
  - 12" (305 mm) Pan Support for Drop-In Refrigerated Wells
  - 20" (508 mm) Pan Support for Drop-In Refrigerated Wells
- Rectangular Full-Size Stainless Steel Food Pans:

- Third-Size (2.5" [64 mm] H)
- Full-Size (2.5" [64 mm] H)
- Full-Size (6" [152 mm] H)
- Half-Size (2.5" [64 mm] H)
- Full-Size (4" [101 mm] H)





# Drop-In Hot/Cold Wells

Models: HCWBI-2DA, -3DA, -4DA, -5DA, -6DA

## All HCWBI-2DA, -3DA, -4DA, -5DA, -6DA Series

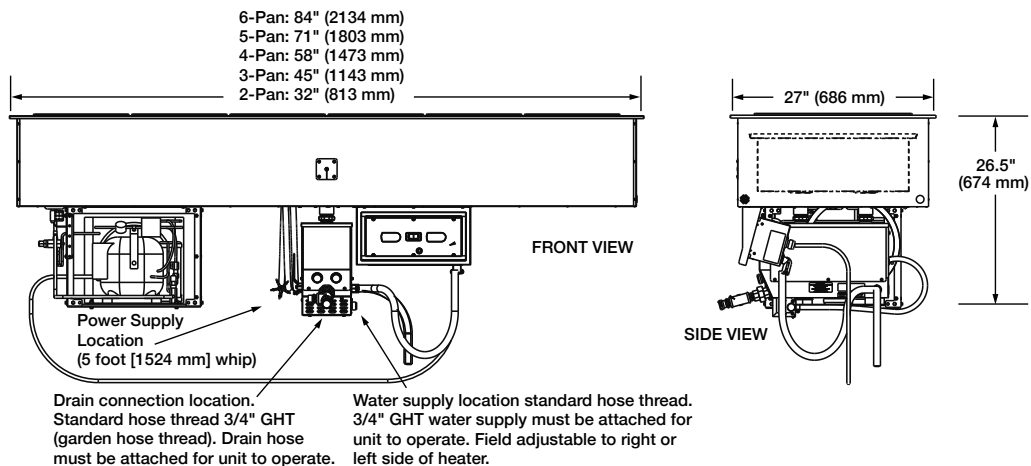

### Cutout Dimensions for Drop-In Hot/Cold Wells

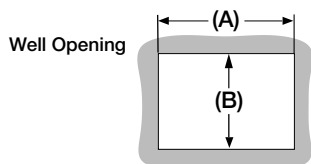

Model	Minimum Width (A)	Maximum Width (A)	Minimum Depth (B)	Maximum Depth (B)
HCWBI-2DA	30.125" (765 mm)	31" (787 mm)	25.19" (640 mm)	26" (660 mm)
HCWBI-3DA	43.125" (1095 mm)	44" (1118 mm)		
HCWBI-4DA	56.125" (1426 mm)	57" (1448 mm)		
HCWBI-5DA	69.125" (1756 mm)	70" (1778 mm)		
HCWBI-6DA	82.125" (2086 mm)	83" (2108 mm)		

## SPECIFICATIONS

### Drop-In Full-Size Insulated Rectangular Models\*

Model	Dimensions (Width x Depth x Height)	Well Height	Compressor Size	Watts	Volts	Amps		Volts	Amps		Plug	Ship Weight*		
						Single Phase	Three Phase		Single Phase	Three Phase				
HCWBI-2DA	32" x 27" x 26.5" (813 x 686 x 674 mm)	12" (305 mm)	1/4 hp	3000	120/208	14.5	8.4	120/240	—	7.3	Hardwired	242 lbs. (110 kg)		
HCWBI-3DA	45" x 27" x 26.5" (1143 x 686 x 674 mm)								—	7.3		268 lbs. (122 kg)		
HCWBI-4DA	58" x 27" x 26.5" (1473 x 686 x 674 mm)		1/3 hp	4000					19.2	11.2		16.7	9.6	309 lbs. (140 kg)
HCWBI-5DA	71" x 27" x 26.5" (1803 x 686 x 674 mm)		1/2 hp	6000					28.8	16.7		—	14.5	351 lbs. (137 kg)
HCWBI-6DA	84" x 27" x 26.5" (2134 x 686 x 674 mm)		28.8	16.7					—	14.5		358 lbs. (162 kg)		

\* Shipping weight includes packaging and is approximate.

\* Contact Hatco for R-513A refrigerant specifications.

## PRODUCT SPECS

### Drop-In Hot/Cold Wells

The Drop-In Hot/Cold Well shall be a Model ...as manufactured by the Hatco Corporation, Milwaukee, WI 53234 U.S.A., the Drop-In Hot/Cold Heated Well shall be rated at ...watts, ...volts, and be ...inches (millimeters) in overall width and be ...inches (millimeters) in overall depth. It shall consist of stainless and aluminized steel housing, electronic control panel (digital temperature display, drain, auto-fill, power light, and 3-position rocker switch (Hot, Off, and Cold), and pan support bars for full-size pans in cold and hot modes.

COLD MODE: A condensing unit utilizing R-404A or R-513A refrigerant, sight glass, service valves, receiver, and a dryer/filter. The digital temperature display for the Cold mode will have a set point of 32°F (0°C) and can be adjusted from 10° to 50°F (-12° to 10°C).

HOT MODE: The patented Hatco FR2 (Bain-Marie) shall consist of 1 to 3 stainless steel tubes wrapped with external heating elements. Each tube may be accessed for cleaning purposes. The unit may be emptied easily by a convenient drain and have a low-water cut-off. The digital temperature display for the Hot mode will have a set point of 192°F (89°C) and can be adjusted from 65° to 192°F (18° to 89°C).

Accessories may include pan support bars, and stainless steel food pans.

Warranty consists of 24/7 parts and service assistance (U.S. and Canada only)

HATCO CORPORATION

(800) 558-0607 | (414) 671-6350

P.O. Box 340500 Milwaukee, WI 53234-0500 U.S.A.

www.hatcocorp.com | support@hatcocorp.com