



Project _____

Item # _____

Quantity _____

Built-In Drawer Warmers - Standard and Narrow

Models: HDW-1B, -2B, -3B
HDW-1BN, -2BN, -3BN

Hold everything from meat to vegetables to rolls in the Hatco Built-In Drawer Warmer. Each drawer features adjustable sliding vents and individual thermostatic controls to hold a wide variety of hot foods safely for peak serving periods.

Standard features

- Available in narrow and standard widths
- Each drawer has a recessed individual thermostatic control, temperature monitor, vent slides and power switch
- Heavy-duty drawer slides with nylon rollers
- Adjustable sliding vents on each drawer
- The pan supplied with each drawer lifts straight out of standard width Drawer Warmers - 20.75" x 12.75" x 6" (527 x 324 x 152 mm)
- Completely insulated individual cavities provide maximum energy efficiency
- Unit comes with 4' (1219 mm) flexible conduit



Options (available at time of purchase only)

Designer Color Drawer Front – Galvanized Steel Standard – Non-standard colors are non-returnable

- Warm Red Black Gray Granite White Granite
- Navy Blue Hunter Green Antique Copper

Controls

- ITC Digital Temperature Control (required on all drawers)
- Touchscreen display control (TTC)
- Oversized Drawer Frame and Pan 20" x 15" x 5" (508 x 381 x 127 mm) (Standard width models only)
- Biscuit Pan Drawer (Accommodates two 18" x 13" (457 x 330 mm) Half-size Sheet Pans – not included) (Standard width models only)
- Chip Guard (HDW-1B, 2B and 3B only)

Accessories

- Custom trivet raises food product .5" (13 mm) off bottom of full size pan 17.5" x 9.5" x .5" (445 x 242 x 13 mm)
- Water/Spillage Pan – one per drawer (excludes BIS Drawer and OS-Pan Options)
- Splash Baffle – one per drawer, Water/Spillage Pan creates humidified environment (excludes BIS Drawer and OS-Pan Options)
- Stainless Steel Food Pans



IFS anti-microbial coatings use naturally-occurring, environmentally sustainable, silver ions to help inhibit the growth of microbes on the powder coated surface. See www.hatcocorp.com/antimicrobial-paint for more information.



For operation, location and safety information, please refer to the Installation and Operating Manual.



HATCO CORPORATION | P.O. Box 340500 Milwaukee, WI 53234-0500 U.S.A. | (414) 671-6350



www.hatcocorp.com | support@hatcocorp.com | [Find a Hatco Rep](#) | [Image Library](#) | [Document Library](#) | [Patents](#) | [Chat](#)



Built-In Drawer Warmers - Standard and Narrow

Models: HDW-1B, -2B, -3B HDW-1BN, -2BN, -3BN

HDW-xB, HDW-xBN

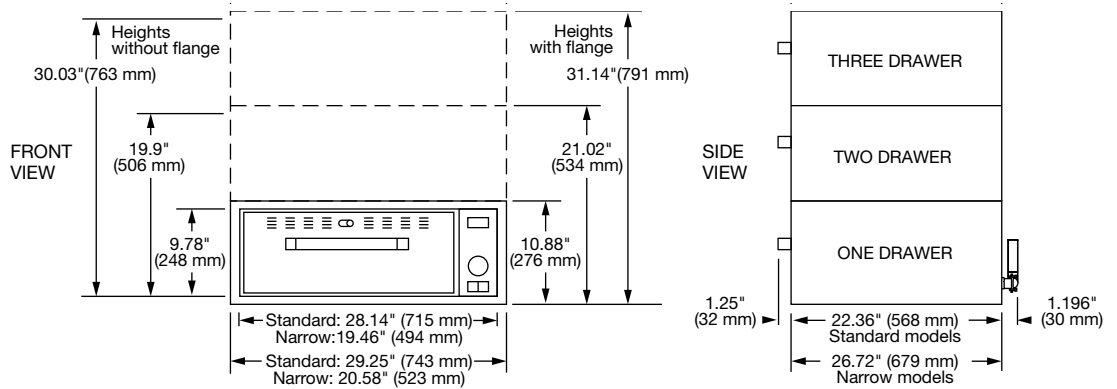

SPECIFICATIONS

Built-In Drawer Warmers - Standard and Narrow

The shaded areas contain electrical information for international models

Model	Dimensions* (Width x Depth x Height)	Volts	Phase	Watts	Amps	Plug	Ship Weight*					
HDW-1B HDW-1BN	28.14" x 22.36" x 9.78" (715 x 568 x 248 mm) 19.46" x 26.72" x 9.78" (494 x 679 x 248 mm)	100	Single	450	4.5	Hardwired with conduit	88 lbs. (40 kg)					
		120			3.8							
		208			2.2							
		HDW-2B HDW-2BN	28.14" x 22.36" x 19.9" (715 x 568 x 506 mm) 19.46" x 26.72" x 19.9" (494 x 679 x 506 mm)	240	Single			450	1.9	Hardwired with conduit	159 lbs. (73 kg)	
				220					2.0			
				240	Single			900	1.9			4.1
				220-230 (CE)					450-492			
230-240 (CE)	413-450			1.8-1.9								
HDW-3B HDW-3BN	28.14" x 22.36" x 30.03" (715 x 568 x 763 mm) 19.46" x 26.72" x 30.03" (494 x 679 x 763 mm)	100	Single	1350	13.5	Hardwired with conduit	232 lbs. (106 kg)					
		120			11.3							
		208			6.5							
		HDW-1BN HDW-2BN HDW-3BN	28.14" x 22.36" x 30.03" (715 x 568 x 763 mm) 19.46" x 26.72" x 30.03" (494 x 679 x 763 mm)	240	Single			1350	5.6	Hardwired with conduit	30.75" (771 mm)	
				220					6.1			
				240	Single			1350	5.6			10.13" (257 mm)
				220-230 (CE)					1350-1476			
230-240 (CE)	1239-1350			5.4-5.6								

• Add 1.14" (29 mm) to width or height for flange. Add 1.25" (32 mm) to depth for drawer handle.
* Shipping weight includes packaging.

Locking Strip position for cut-out requirements

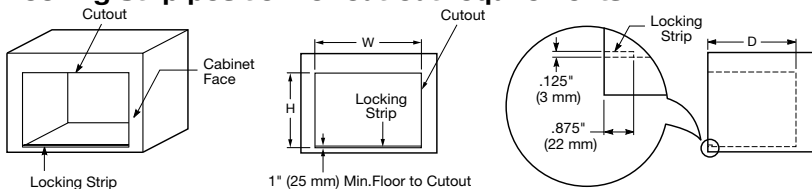

Built-In Cut-Out Requirements

Model	Width	Depth [▲]	Height
HDW-1B	28.375"	24"	10.13" (257 mm)
HDW-2B	(720 mm)	(610 mm)	20.25" (514 mm)
HDW-3B			30.75" (771 mm)
HDW-1BN	19.7"	28.375"	10.13" (257 mm)
HDW-2BN	(500 mm)	(720 mm)	20.25" (514 mm)
HDW-3BN			30.75" (771 mm)

▲Depth dimension includes 1.5" (38 mm) for conduit connector.

PRODUCT SPECS

Built-In Drawer Warmers - Standard and Narrow

The Drawer Warmers shall be a Hatco Model ... , built-in as manufactured by the Hatco Corporation, Milwaukee, WI 53234, U.S.A.

The unit shall have ... drawer(s) and be rated at ... watts, ... amps. Built-In model with 4' (1219 mm) flexible conduit.

The Drawer Warmer shall have a stainless steel exterior, interior, drawer slides, and assembly. Drawer rollers shall be durable nylon. The drawer assembly shall fully extend to allow removal of pans without tilting in standard width models.

The unit shall be individually insulated top, bottom and sides of cabinet. Each unit shall have individual power switch, thermostat and temperature monitor for each drawer. Options: Seven Designer Colors for Front Drawer(s), ITC Digital Temperature Control, Touchscreen Display Control, Oversized Drawer Frame and Pan, Biscuit Pan Drawer, Chip Guard. Accessories: Custom Trivet, Water/Spillage Pan, Splash Baffle, Stainless Steel Food Pans.

Warranty consists of 24/7 parts and service assistance (U.S. and Canada only).

HATCO CORPORATION

P.O. Box 340500 Milwaukee, WI 53234-0500 U.S.A. | (414) 671-6350



www.hatcocorp.com

support@hatcocorp.com

[Find a Hatco Rep](#)

[Image Library](#)

[Document Library](#)

[Patents](#)

[Chat](#)