



Project _____

Item # _____

Quantity _____

Palletti® Countertop Induction Warmers

Models: IWRM-C1-1317-06, IWRM-CD1-03, -05

Hatco's patented Palletti® Countertop Professional Induction Warmers offer a safe, efficient and attractive way to keep hot foods hot. Perfect for serving applications such as buffet lines and hospitality suites. The warmer has five simple and precise settings, which allow for a wide variety of foods to be held both safely and at optimum quality. The units are also memory retentive, so once turned off and back on, the last setting will resume.

This unit has a low-profile and ultra-thin design in all black, so the focus remains on the food rather than the equipment. Choose either the stand-alone countertop (120V only) which offers the greater 600 watts of power for large volumes or the lower watt daisy chain countertop unit where multiple units can be interconnected.

Standard features:

- Portable and adaptable for buffets and many other front-of-the-house applications to give the most attractive and visible food presentations
- Energy efficient, quiet and safe operation with no open flames as with traditional warming presentations
- Pan Sense Technology (PST) activates the unit only when a suitable pan is placed on top
- Contemporary, low-profile design with a Bold Black housing and durable, black glass-ceramic top that is easy to clean
- Features a control panel with a standby key, temperature control arrow keys and temperature setting indicators
- Automatic shut-off to prevent overheating

• IWRM-C1-1317-06

– Greater power for large volume applications

• IWRM-CD1-03, -05

– Low wattage warmers which can be interconnected with multiple units to one electrical outlet resulting in great energy efficiency and a simple cord management system

– Maximum number of interconnected units:

IWRM-CD1-03: 5 for the US and 4 for Canada

IWRM-CD1-05: 5 units with SCHUKO and BS plugs and 4 units for units with CCC and AU plugs

– 17" (432 mm) interconnect cord



For operation, location and safety information, please refer to the Installation and Operating Manual.



CE approvals for only IWRM-CD1-05 except 220/60 volts option)

HATCO CORPORATION

P.O. Box 340500 Milwaukee, WI 53234-0500 U.S.A. | (414) 671-6350



www.hatcocorp.com

support@hatcocorp.com

[Find a Hatco Rep](#)

[Image Library](#)

[Document Library](#)

[Patents](#)

[Chat](#)



Palletti® Countertop Induction Warmers

Models: IWRM-C1-1317-06, -CD1-03, -05

IWRM-C1-1317-06 Model

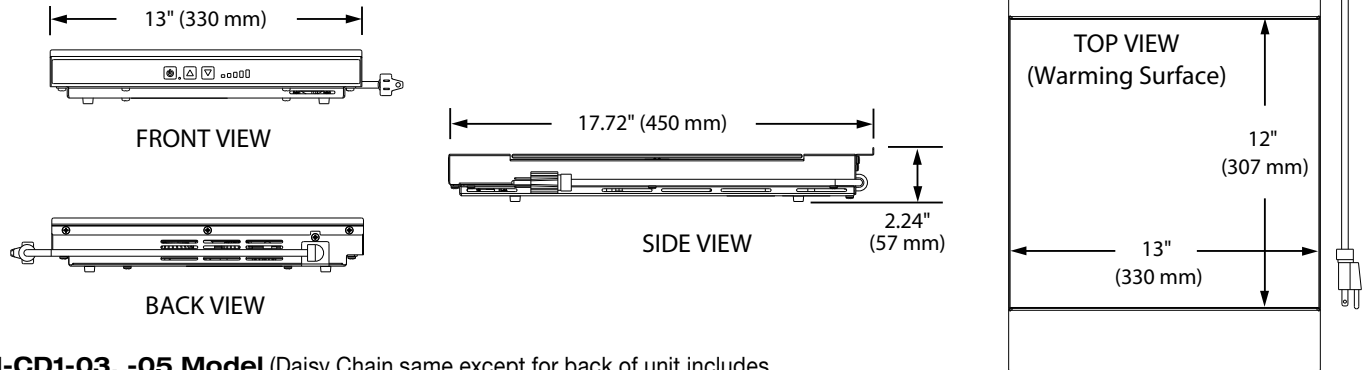

IWRM-CD1-03, -05 Model (Daisy Chain same except for back of unit includes circuit breaker)

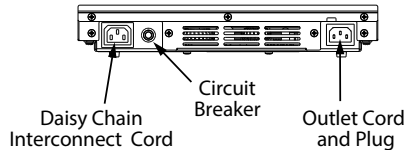

SPECIFICATIONS Countertop Induction Warmers

Model	Dimensions (Width x Depth x Height)	Volts	Phase	Watts	Hz	Amps	Maximum Number of Interconnected Warmers	Plug and Cord Location	Approx. Ship Weight
IWRM-C1-1317-06	13" x 17.72" x 2.24" (330 x 450 x 57 mm)	120	1	600	50-60	5.0	Not Available	NEMA 5-15P (Rear right bottom base corner)	12 lbs. (5.5 kg)
IWRM-CD1-03	13" x 17.72" x 2.24" (330 x 450 x 57 mm)	120	1	360	50-60	3.0	US: 5 units interconnected CAN: 4 units interconnected	NEMA 5-15P (Rear right bottom base corner)	12 lbs. (5.5 kg)
IWRM-CD1-05				500		2.3/2.2/2.1	5 units interconnected 4 units interconnected	BS-1363, CEE 7/7 Schuko, AU, CCC (10A)	
				500		2.3	5 units interconnected	BS-1363	

PAN SIZE

Maximum Pan Size: 13" diameter (330 mm), Minimum Pan Size: 4" diameter (102 mm).

PLUG CONFIGURATIONS

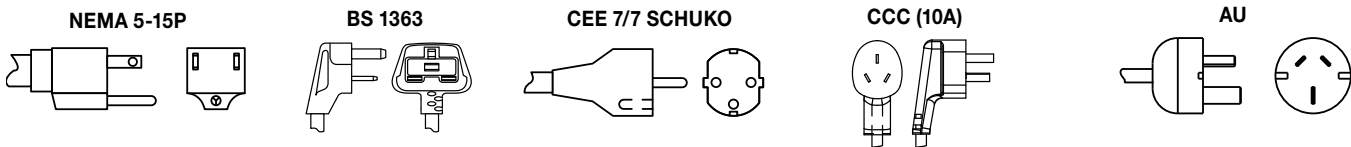

PRODUCT SPECS Palletti® Countertop Induction Warmers

The Countertop Induction Warmer shall be a Palletti® model, manufactured by the Hatco Corporation, Milwaukee, WI 53234 U.S.A. The Induction Warmer shall be rated at ... watts, ... volts, single phase and be ... inches (millimeters) in overall width. The Countertop Induction Warmer shall consist of a painted stainless steel housing with an aluminum base with a single generator coil and a glass-ceramic top surface. It includes an ON/OFF button and 5 power levels.

A 71" (1800 mm) cord and plug is included. For the Daisy Chain Countertop Warmer a 17" (450 mm) interconnected cord is included.

Warranty consists of 24/7 parts and service assistance (US and Canada only).

HATCO CORPORATION | P.O. Box 340500 Milwaukee, WI 53234-0500 U.S.A. | (414) 671-6350



www.hatcocorp.com | support@hatcocorp.com | [Find a Hatco Rep](#) | [Image Library](#) | [Document Library](#) | [Patents](#) | [Chat](#)