



Project _____

Item # _____

Quantity _____



Countertop Shields - Front Units and Side Unit

Front Shield Models: CTS-3012, -3612, -4212, -4812
Side Shield Model: CTS-0815,

Hatco's lightweight, clear, transparent Countertop Shields can help in efforts to prevent the spread of germs and viruses. It is uniquely designed for buffet areas and can also help at checkout registers, restaurants, pharmacies and other areas. It acts as a physical barrier that can limit the passing of contagions at customer interaction points. Clear partitions are more important than ever. Countertop Shields can stand on their own and do not require tools for assembly. If desired, Support Stand Brackets can be secured to surface using the mounting screw holes. Extremely versatile, they can be configured to the shield you need!

Standard features

- Helps maintain social distance and physical separation
- Helps protect customers and employees
- Easily sanitized using non-abrasive cleaners
- Completely transparent/clear - will not obscure vision
- More impact resistant than glass
- Customizable configurations to fit your space
- Durable, light weight and portable
- Easy to install
- Front Shield unit is 0.22" (5.6 mm) thick acrylic with rounded edges and comes with two Support Stand Brackets with four 0.25" (6 mm) holes for optional mounting
- Side Shields are 0.22" (5.6 mm) thick acrylic with rounded edges, sold in pairs and include two Support Stand Brackets

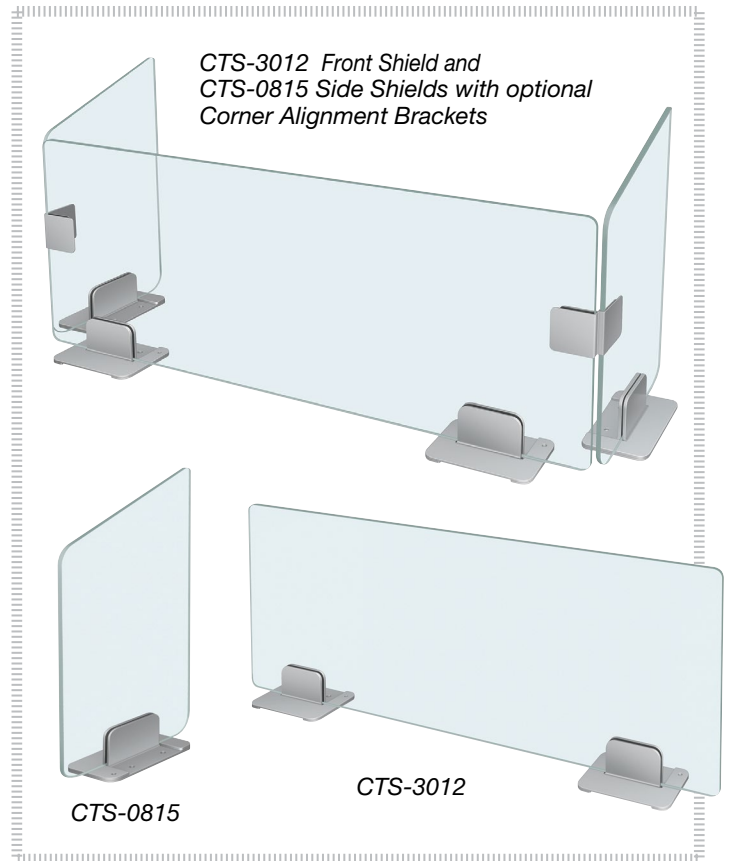

Options

Designer Color for Support Stand Bracket (see illustration on next page for clarification) made of 12 gauge stainless steel – Brushed stainless steel Standard – Non-standard colors are non-returnable

Warm Red Black Gray Granite White Granite
 Navy Blue Hunter Green Antique Copper

Accessories

- Straight Alignment Bracket (see illustration on next page for clarification) in 12 gauge stainless steel – Brushed stainless steel Standard
Designer Color – Non-standard colors are non-returnable
 - Corner Alignment Bracket (see illustration on next page for clarification) made of 12 gauge stainless steel – Brushed stainless steel Standard
Designer Color – Non-standard colors are non-returnable
 - Support Stand Bracket (see illustration on next page for clarification) made of 12 gauge stainless steel – Brushed stainless steel Standard
Designer Color – Non-standard colors are non-returnable
- Warm Red Black Gray Granite White Granite
 Navy Blue Hunter Green Antique Copper

 IFS anti-microbial coatings use naturally-occurring, environmentally sustainable, silver ions to help inhibit the growth of microbes on the powder coated surface. See www.hatcocorp.com/antimicrobial-paint for more information.



HATCO CORPORATION | P.O. Box 340500 Milwaukee, WI 53234-0500 U.S.A. | (800) 558-0607 | (414) 671-6350

 www.hatcocorp.com | support@hatcocorp.com | [Find a Hatco Rep](#) | [Image Library](#) | [Document Library](#) | [Chat](#)



Countertop Shield

Front Shield Models: CTS-3012, -3612, -4212, -4812

Side Shield Model: CTS-0815

CTS-3012, -3612, -4212, -4812

FRONT SHIELD

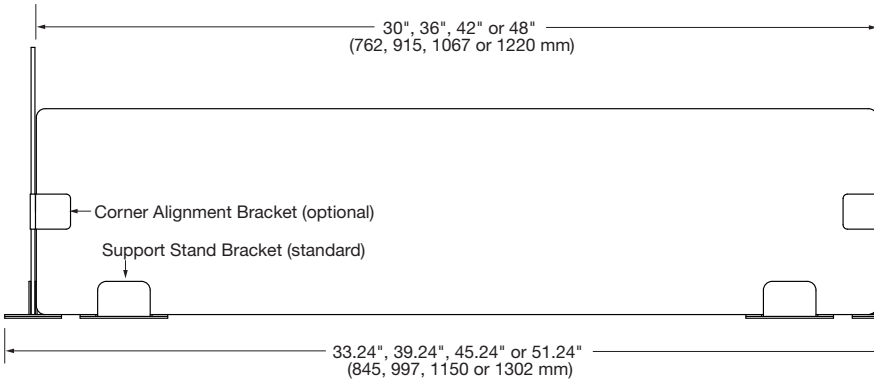

CTS-0815

SIDE SHIELD

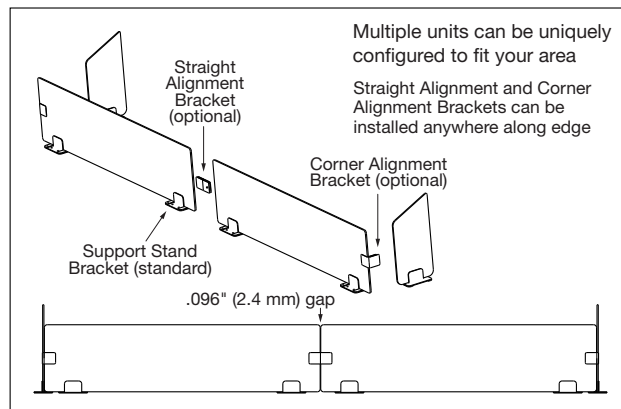
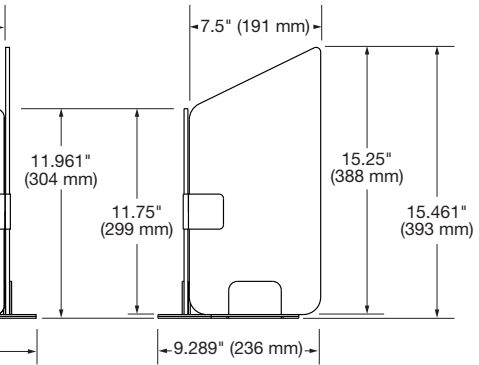

SPECIFICATIONS Countertop Shield

Model	Model Dimensions W* x D x H [▲]	Package Dimensions W x D x H	Approximate Shipping Weight
Front Shields*			
CTS-3012	30" x 7.5" x 11.961" (762 x 191 x 304 mm)	50" x 5" x 14" (1270 x 127 x 356 mm)	8 lbs. (4 kg.)
CTS-3612	36" x 7.5" x 11.961" (915 x 191 x 304 mm)	50" x 5" x 14" (1270 x 127 x 356 mm)	9 lbs. (5 kg.)
CTS-4212	42" x 7.5" x 11.961" (1067 x 191 x 304 mm)	50" x 5" x 14" (1270 x 127 x 356 mm)	10 lbs. (5 kg.)
CTS-4812	48" x 7.5" x 11.961" (1220 x 191 x 304 mm)	50" x 5" x 14" (1270 x 127 x 356 mm)	10 lbs. (5 kg.)
Side Shield*			
CTS-0815	8" x 7.5" x 15.461" (762 x 191 x 393 mm)	Pending	Pending

* Acrylic is 0.22" (5.6 mm) thick

* Add 3.24" (83 mm) to width for mounting bracket feet

▲ Height includes Support Stands

PRODUCT SPECS Countertop Shield

The Countertop Shield shall be a Hatco model ... , as manufactured by the Hatco Corporation, Milwaukee, WI 53234, U.S.A.

The Front Shield units shall have ... a 0.22" (5.6 mm) thick acrylic shield with two 12 gauge Support Stand Brackets available in standard brushed stainless steel or optional *Designer Color*. The Side Shield unit shall have ... two 0.22" (5.6 mm) thick acrylic shields with two 12 gauge Support Stand Brackets available in standard brushed stainless steel or optional *Designer Color*.

Options shall include Straight Alignment Brackets and Corner Alignment Brackets. The Optional Straight Alignment and Corner Alignment Brackets shall be installed anywhere along the edge of the acrylic Front Shield. They are available in standard Brushed stainless steel or optional *Designer Color*. All accessory Support Stand Brackets shall have four .25" (6 mm) screw holes for optional mounting.

HATCO CORPORATION

P.O. Box 340500 Milwaukee, WI 53234-0500 U.S.A.

(800) 558-0607

(414) 671-6350



www.hatcocorp.com

support@hatcocorp.com

[Find a Hatco Rep](#)

[Image Library](#)

[Document Library](#)

[Chat](#)