



Project _____

Item # _____

Quantity _____

Flav-R-Shield® Portable Adjustable Sneeze Guards - Model ALLIN1

Item Numbers: ALLIN1-24, -36, -48, -60, -72

Enhance and protect food products simultaneously with Hatco's Flav-R-Shield® Sneeze Guards – ALLIN1 for flexible and portable self-service applications. These extremely versatile, stylish yet functional Sneeze Guards with several patented features are ideal for buffet lines, serving stations and especially for events. They safeguard your food plus collapse flat for easy storage.

Standard features

- Unit is a single bay, super adjustable, collapsible, flat stack, portable model
- Patented, durable and collapsible 0.25" (6.4 mm) Thick acrylic Face Panel with polished edges, 0.75 (19 mm) radius corners and is 14" (335 mm) High
- Patented, adjustable push-button hinges with 15° incremental locking, allow the acrylic Face Panel to meet almost any configuration
- Three attached, pivoting 0.5" (13 mm) Thick 10" High (254 mm) machined brushed aluminum Leg segments



Customize now!

Custom configurations available:
Hardware, glass, lighting and more!
Scan or click the QR code to the left.
www.hatcosneezeguards.com



HATCO CORPORATION | P.O. Box 340500 Milwaukee, WI 53234-0500 U.S.A. | (414) 671-6350



www.hatcocorp.com | support@hatcocorp.com | [Find a Hatco Rep](#) | [Image Library](#) | [Document Library](#) | [Patents](#) | [Chat](#)



Flav-R-Shield® Portable Adjustable Sneeze Guards - Model ALLIN1
 ALLIN1-24, -36, -48, -60, -72

Model ALLIN1 Standard offerings

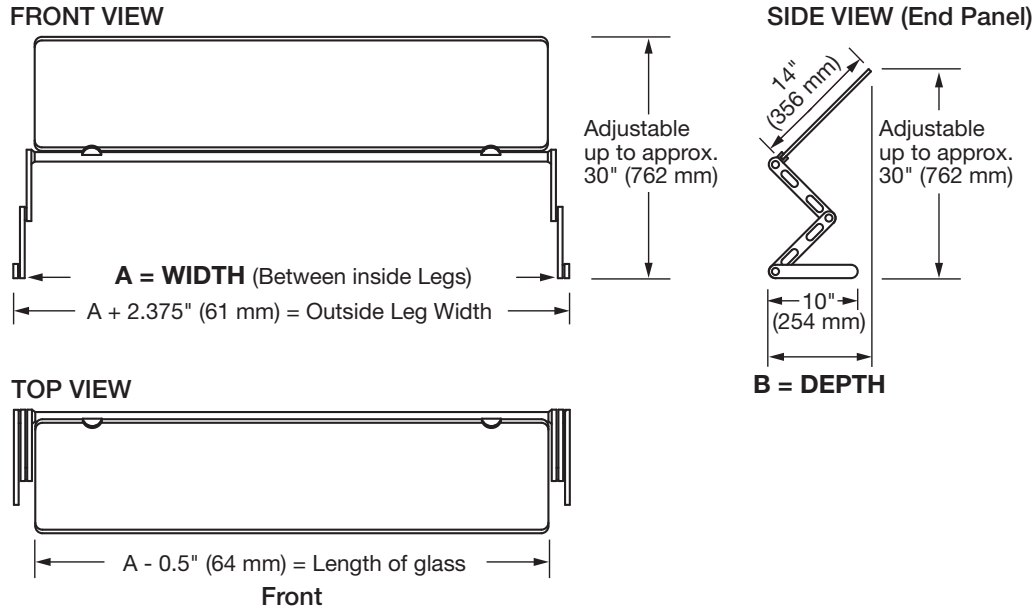

SPECIFICATIONS
Flav-R-Shield® Portable Adjustable Sneeze Guards - Model ALLIN1

| Number of Bays | Item Number | A Width From inside leg to inside leg | B Depth | Height | Approx. Ship Weight [■] |
|----------------|-------------|--|---|------------------------------------|----------------------------------|
| 1 | ALLIN1-24 | 26.5" (673 mm) | 10" to approx. 15.25" (254 to approx. 388 mm) | Adjustable to approx. 30" (762 mm) | 13 lbs (6 kg) |
| 1 | ALLIN1-36 | 38.5" (978 mm) | 10" to approx. 15.25" (254 to approx. 388 mm) | Adjustable to approx. 30" (762 mm) | 19 lbs (9 kg) |
| 1 | ALLIN1-48 | 50.5" (1283 mm) | 10" to approx. 15.25" (254 to approx. 388 mm) | Adjustable to approx. 30" (762 mm) | 25 lbs (12 kg) |
| 1 | ALLIN1-60 | 62.5" (1588 mm) | 10" to approx. 15.25" (254 to approx. 388 mm) | Adjustable to approx. 30" (762 mm) | 50 lbs (23 kg) |
| 1 | ALLIN1-72 | 74.5" (1893 mm) | 10" to approx. 15.25" (254 to approx. 388 mm) | Adjustable to approx. 30" (762 mm) | 60 lbs (28 kg) |

■ Items may be shipped in multiple boxes.

PRODUCT SPECS
Flav-R-Shield® Portable Adjustable Sneeze Guards - Model ALLIN1

Flav-R-Shield® Portable Adjustable Sneeze Guard – Model ALLIN1 shall be manufactured by the Hatco Corporation, Milwaukee, WI 53234 U.S.A.
 The unit shall be ... inches (millimeters) in overall width, ... inches (millimeters) in overall depth and ... inches (millimeters) in overall height.
 The Sneeze Guard shall be a single bay, super adjustable, collapsible, flat stack, portable model with patented, durable and collapsible 0.25" (6.4 mm) Thick acrylic

Face Panel with polished edges and 0.75 (19 mm) radius corners and is 14" (335 mm) Deep. Unit shall have patented adjustable push-button hinges with 15° incremental locking, allowing the acrylic Face Panel to meet most configurations, three attached, pivoting 0.5" (13 mm) Thick 10" High (254 mm) machined brushed aluminum Leg segments.
 Warranty consists of one (1) year parts only.

HATCO CORPORATION | P.O. Box 340500 Milwaukee, WI 53234-0500 U.S.A. | (414) 671-6350



www.hatcocorp.com | support@hatcocorp.com | [Find a Hatco Rep](#) | [Image Library](#) | [Document Library](#) | [Patents](#) | [Chat](#)